

# MASTER GEAR AGGREGATE PLATFORM LIFT

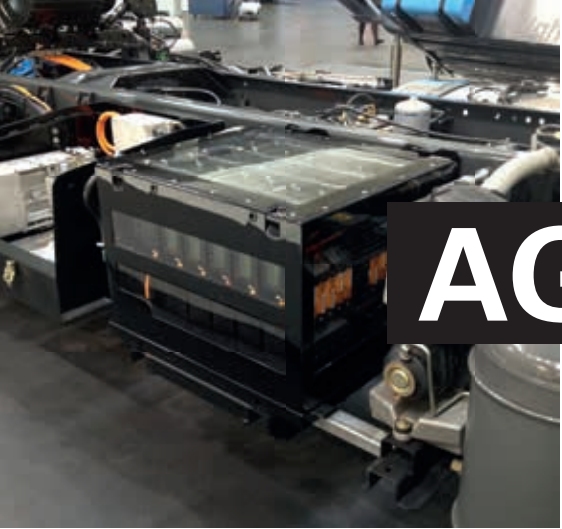

HYDRAULIC



**Blitz**<sup>®</sup>

# FEATURES

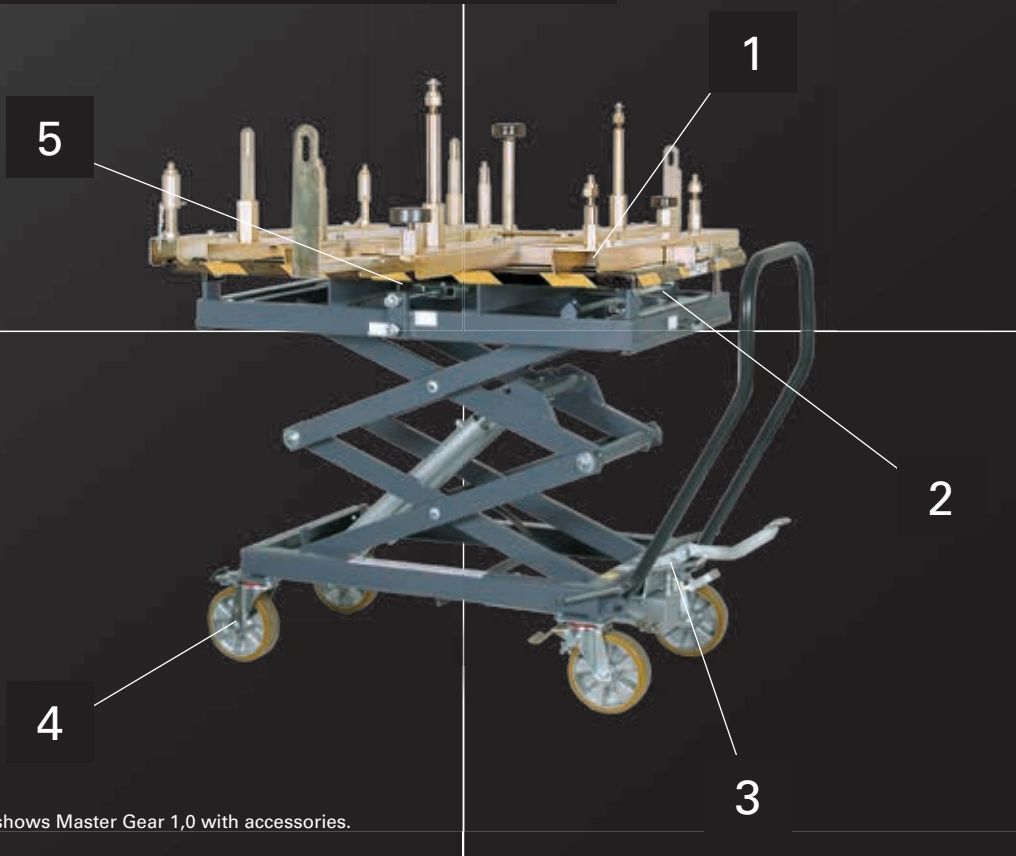

Figure shows Master Gear 1,0 with accessories.

- **1. LOCATION HOLES** Additional, vehicle-specified tools, can be firmly fastened to the platform surface by means of the continuous location hole matrix.
- **2. SAFETY** The generous base of the Master Gear lifting platform ensures high stability and therefore enables safe and exact work.
- **3. COMPLETELY FOOT-OPERATED** The integrated sink brake valve allows an exact control of the lowering speed. The load stroke is foot-hydraulic.
- **4. FULLY MOBILE** Generously sized rollers – 2 fixed, 2 swivelling with integrated locking brakes – provide mobility at work.
- **5. VARIODESK** The supporting platform surface of the Master Gear is not only extensive but also offers diverse adjustment possibilities due to a flexibility of  $\pm 20$  mm in x- and y-axis and a tilting angle of  $\pm 2^\circ$ .

## MASTER GEAR 1,0

## MASTER GEAR 2,0

LOAD STROKE  
PRECISION STROKE

FOOT HYDRAULIC  
FOOT HYDRAULIC

ELECTRO HYDRAULIC  
HAND HYDRAULIC

CAPACITY

1000 KG

2000 KG

STROKE

1330 MM

1000 MM

**A** LENGTH

1260 MM

1700 MM

**B** WIDTH

720 MM

800 MM

**C** HEIGHT MIN.

635 MM

730 MM

HEIGHT MAX.

1965 MM

1730 MM

WEIGHT

290 KG

550 KG

ADJUSTMENT CAPACITY

$\pm 20$  MM

$\pm 20$  MM

INCLINE CAPACITY

$+ 2^\circ$

$+ 2^\circ$

**Universally Adjustable** Due to construction, modern vehicle aggregates can only be removed and/or mounted via the underside of the vehicle. The new aggregate platform lifts of the Master Gear series are ideally suited to this field of application.

The Master Gear excels itself thanks to the manifold adjustable and tiltable supporting platform VarioDesk. Even the mounting of complete exhaust systems can be easily carried out by one person alone.

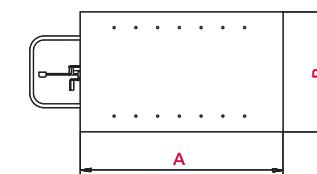
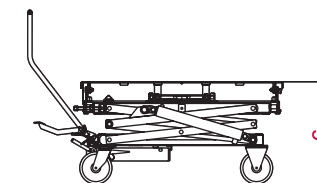

## MASTER GEAR 2,0



BlitzRotary GmbH  
Hüfingerring Straße 55  
D-78199 Bräunlingen  
Telefon +49.771.9233.0  
Telefax +49.771.9233.99  
info@blitzrotary.com  
www.blitzrotary.com

A DOVER COMPANY

