



# OKU

## Stud Gun

### Automatic Stud Gun AS-8, AS-9

#### Operating instructions

(ID-No. 00035101)

00100251 AS-8 (gun for manual use)

00100257 AS-8 (gun for machine)

00100252 AS-9 (gun for manual use)

00100258 AS-9 (gun for machine)

assembled:

Date: \_\_\_\_\_

Name: \_\_\_\_\_

## Table of contents

Table of contents .....	2
1 Preface and general information .....	3
1.1 General .....	3
1.2 Scope of supply .....	3
1.3 Intended use .....	3
1.4 Liability .....	4
1.5 Warranty .....	4
2 Safety information .....	5
2.1 Personnel responsible for safety .....	5
2.1.1 Operator .....	5
2.1.2 Qualified personnel .....	5
2.2 General safety instructions .....	6
2.3 Layout of the safety instructions .....	6
3 Technical Data .....	8
3.1 Stud types .....	8
3.2 Dimensions and weight .....	8
3.3 Noise emission .....	8
3.4 Ambient conditions .....	8
4 Commissioning .....	9
4.2 Pneumatic connection .....	9
5 Operation of the gun .....	10
5.1 Insertion of studs .....	10
5.2 Faults during insertion .....	11
5.2.1 Studs inserted to deep .....	11
5.2.2 Studs jut out off the tire .....	11
5.3 Conversion of machine gun to manual gun .....	11
6 Faults and troubleshooting .....	14
7 Lubrication and maintenance .....	15
7.1 Lubrication .....	15
7.1.1 Lubricating oil .....	15
7.1.2 Lubricating grease .....	15
7.2 Greasing points .....	16
7.3 Maintenance .....	16
8 Shutdown and dismounting .....	17
9 Spare and wear parts .....	18
9.1 Requirements .....	18
9.2 Handling of order .....	18
9.3 Explanation to the spare parts list .....	18
9.4 Spare parts-set .....	18
9.5 Exploded drawing AS-8 .....	19
9.6 Spare parts list AS-8 .....	20
9.7 Exploded drawing AS-9 .....	21
9.8 Spare parts list AS-9 .....	22
10 Appendix .....	23
10.1 CE-Declaration of Conformity .....	23
10.2 Copyright .....	24
10.3 Manufacturer and contact person .....	24

# 1 Preface and general information

## 1.1 General

The operating instructions is used for safe operation of the Stud Guns (in the following referred to as "gun") type Automatic Stud Gun AS-8 and AS-9 (ID-No. 00100251, 00100252, 00100257, 00100258). The safety instructions included hereinafter must be observed.

The operating instructions must be available for anybody who is working with the gun and the included instructions must be carefully attended to.

The operating instructions must always be complete and perfectly readable.

## 1.2 Scope of supply

The delivery normally consists of a stud gun, the operating instruction and a kit of spare parts consisting of: 3 spreader fingers, 3 insertion pins and 1 spring lock.

The parts included in your delivery are stated in the accompanying papers. These papers shall be checked for conformity, immediately after receipt of the goods.

OKU GmbH does not provide any guarantee and/or accept any liability for defects complained belatedly.

Therefore:

- Contact the forwarder immediately to complain visible transit damages
- Contact OKU GmbH immediately to complain visible defects and/or incompleteness of delivery.

## 1.3 Intended use

The gun is intended to be used only for the insertion of spikes into tyres of cars.

**Any other use shall be deemed to be inappropriate!**

## 1.4 Liability

The information, data and notes of this operating instruction were up-to-date when passing for press. The specifications, illustrations and descriptions included hereinafter do not apply for any previously supplied guns.

We do not accept liability for damages and operating troubles caused by:

- inappropriate use
- unauthorized modification of gun
- improper operation of the gun
- operating errors
- disregard of this operating instructions

## 1.5 Warranty

Conditions of warranty: see Standard Terms and Conditions of OKU GmbH.

Assert warranty claims against OKU GmbH immediately after detection of the defect.

Warranty claims expire in each case in which liability claims cannot be made.

## 2 Safety information

### 2.1 Personnel responsible for safety

#### 2.1.1 Operator

Operator is called any natural or legal person who is using the gun and/or on behalf of whom the gun is used.

The operator and/or his safety officer must ensure,

- observance of the relevant regulations, instructions and laws,
- only qualified personnel is working with the gun,
- personnel having the operating instructions available at any time,
- to prohibit non-qualified personnel from working with the gun.

#### 2.1.2 Qualified personnel

As qualified personnel are to be considered persons who were authorised by the safety officer of the plant to perform the necessary activities and who are able to recognise and avoid potential hazards because of their education, experience, instructions and their knowledge about corresponding standards and rules for the prevention of accidents as well as operating conditions (see IEC 364, definition for qualified personnel).

## 2.2 General safety instructions

These safety instructions do not claim to be exhaustive. In case of any questions, please, contact OKU.

At the time of delivery the gun is state of the art and reliable.

The gun is a source of danger for persons, for the gun itself and for other material assets of the operator, if

- it is operated by unqualified personnel
- it is used inappropriately



Operate the gun only when it is in good condition.

Any upgrade, modification or redesign of the gun is basically prohibited. In this case, please confer with OKU.

## 2.3 Layout of the safety instructions

The safety instructions described hereinafter are arranged consistently

### Beware of personal injury

Pictogram	Meaning	Signal words	Notes
	Warning for hazardous electrical voltage	<b>Danger!</b>	Warns of <b>imminent danger</b> . Consequences of disregarding: Death or very severe injuries
	Warning for general danger	<b>Warning!</b>	Warns of a <b>potential, very hazardous situation</b> . Consequences if disregarded: Death or very severe injuries
	Warning for a general danger	<b>Caution!</b>	Warns of a <b>potential hazardous situation</b> . Consequences if disregarded: Light or minor injuries

### Warning of material damage

Icons used	Meaning	Signal words	Notes
	Warning of material damage	<b>Stop!</b>	Warns of <b>potential material damage</b> . Consequences if disregarded: Ambient damage or damage of the gun.

### Other information

Icons used	Meaning	Signal words	Notes
	General note	<b>Note!</b>	Designates a general, useful note. Adherence hereof will ease the use of the gun.

## 3 Technical Data

### 3.1 Stud types

The gun can be used for the insertion of single-flange studs into car tires.

Type	ID.-No.	Stud sizes
AS-8 (gun for manual use)	00100251	Ø8 all lengths
AS-8 (gun for machine)	00100257	
AS-9 (gun for manual use)	00100252	Ø8 from length of 11 mm Ø9 from length of 11 mm
AS-9 (gun for machine)	00100258	

### 3.2 Dimensions and weight

The following values are valid for the gun without any accessories and can differ according to the respective extra equipment.

Length	ca. 220 mm
Width	ca. 60 mm
Height	ca. 185 mm
Weight	ca. 1,5 kg

### 3.3 Noise emission

The sound pressure level at the work station of the operator can reach up to 83 dB(A). Provide suitable ear protection for the operator.

### 3.4 Ambient conditions

Use the gun only in closed and dry rooms.

The permissible ambient temperature during operation is from 10 °C to 40 °C.



## 4 Commissioning

Precautions to be taken before start working with the gun

- Check gun for proper condition.
- Do never operate a damaged gun.

### 4.2 Pneumatic connection



#### Attention!

The pneumatic connection is to be made by qualified personnel with extensive knowledge in handling of pneumatic systems.

Screw provided coupling (9) onto the hand grip. Plug compressed air hose into coupling. The gun requires compressed air with approx. 7-8 bar working pressure. The maximum operating pressure amounts to 10 bar.



Coupling (9) for compressed air connection

## 5 Operation of the gun

### 5.1 Insertion of studs

**Without feeding unit:** fill the feeding pipe (10) with approx. 10 studs (flange leading).

**With feeding unit:** connect the gun with the feeding hose of the studs until feeding pipe is filled with studs (flange leading).

Moisten tire with low surface tension water. To get this, mix normal tap water with some drops of usual dish liquid.



**Tip!**

**Use only less dish liquid to avoid that the inserted stud is pulled out again when extracting the gun.**

Insert spreader fingers into one of the moistened tyre holes. Operate the trigger (3) and keep it pressed. The stud is pressed into the tire. Release trigger (3); the gun is now loosen from the tire and the stud is inserted.



**Tip!**

**Put some pressure onto the gun when inserting the studs. With some practice and skill you'll soon find the respective pressure which shall be applied to reach a steady result.**

## 5.2 Faults during insertion

### 5.2.1 Studs inserted to deep

Reduce the pressure applied on the gun during insertion.

### 5.2.2 Studs jut out off the tire

Put more pressure onto the gun when inserting the studs.

## 5.3 Conversion of machine gun to manual gun

If you are using a studding machine (AS-ZN, EP-ZN or EPK-ZN) and want to dismantle the gun from the base frame to use it manually you'll firstly have to convert the gun, i.e. to release trigger and replace (AS-8) or remove (AS-9) the spacer ring.

Please do as follows:



**Caution!**

**Disconnect the gun from the compressed air supply.**

**Release trigger (AS-8 and AS-9):** Slip off O-ring (8) from bushing (2) and dowel pin (7) appears. The dowel pin can be easily pushed out of the bore. The trigger (3) is released and can be removed. Turn the trigger by 90° and insert it back into the bushing. Then insert the dowel pin into the bore of the bushing. Slip the O-ring over and place it into the groove.

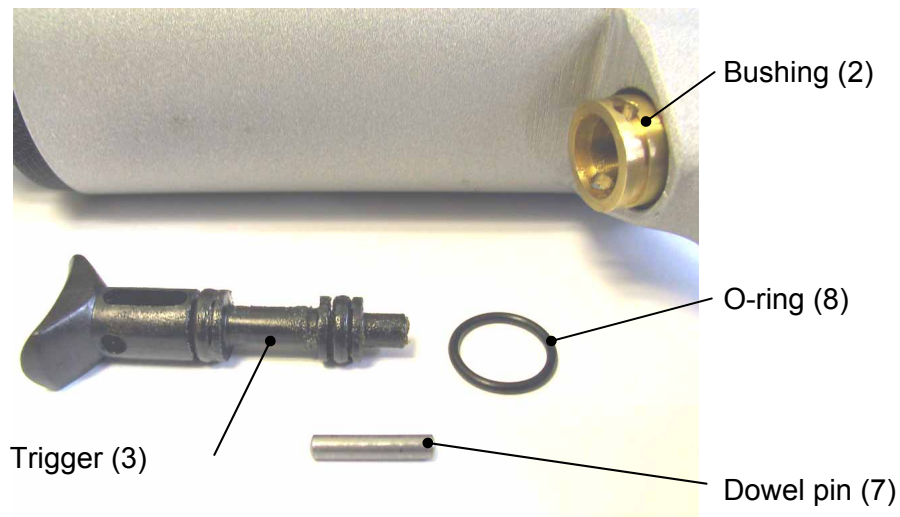
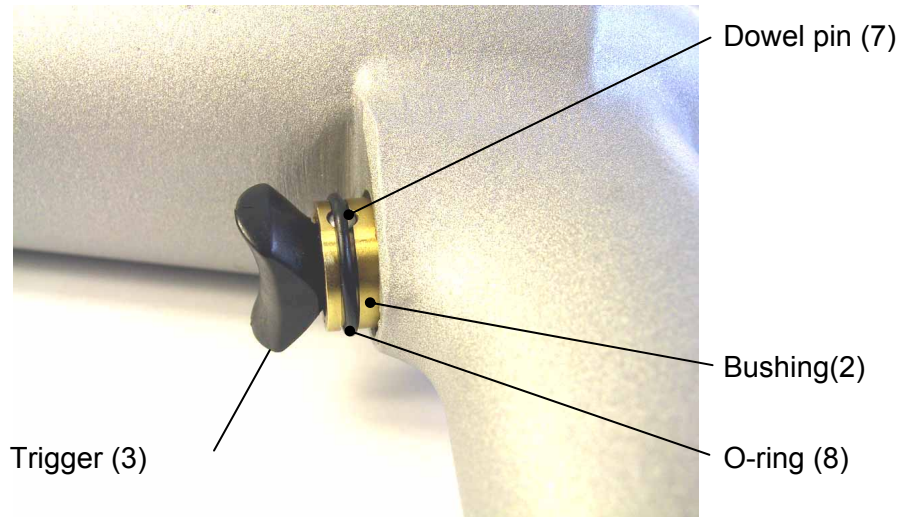

**Replace and/or remove the spacer ring:** to do this the gun needs to be partially disassembled.



**Caution!**

**When unscrewing the lock nut, it must be held tight, because of the strong compression spring which is in the gun. If not, the lock nut would jump out together with the spreader fingers and pose great danger.**

**Replace spacer ring (AS-8):** Unscrew lock nut (21) from gun (1); the compression spring (25) and spacer ring (19) appear. Replace the existing spacer ring with the spacer ring for manual operation of the gun (special accessories ID.-No. 00350733) and screw lock nut (21) again onto the gun.

**Remove spacer ring (AS-9):** Unscrew lock nut (20) from gun (1); the compression spring (25) and spacer ring (19) appear. Remove the existing spacer ring and screw lock nut (20) again onto the gun.

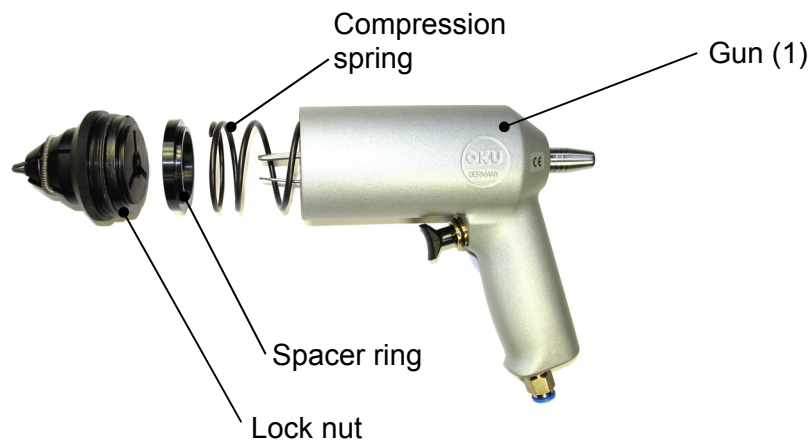

**Stop!**

**The gun must be set back to its initial state should you want to use it on the studding machine.**

## 6 Faults and troubleshooting

Cause	Trouble shooting
Deformed or dirty stud jammed in feeding pipe or gun head.	Unscrew lock nut ( <b>caution!</b> ) and take the head off the gun. Now remove the jammed stud.
Stud in feeding pipe (10) in wrong position (with shank leading)	Remove feeding tube and shake out stud
Trigger (3) get caught	Remove O-Ring (8) and dowel pin (7) and then trigger (3). Clean and lubricate trigger slightly with oil. Check if compression spring (6) broken, if so replace compression spring.
Worn spreader fingers	Remove spring lock and replace spreader fingers
Worn insertion pin (17)	Unscrew lock nut ( <b>caution!</b> ) and take the head off the gun. Remove feeding tube (10) and piston (14) and replace insertion pin (17) by a new one.
Worn separating finger (22)	Remove spring lock and replace separating finger by a new one.

## 7 Lubrication and maintenance

### 7.1 Lubrication



**Stop!**

**Observe the effective directions for the use and safety of the applied lubricants!**

#### 7.1.1 Lubricating oil

Distinguishing mark acc. to DIN 51502	Designation	ISO-Viscosity Index DIN 51519	Manufacturer
AN 22	Normal lubricating oil	ISO VG 22	AVIA (AVILUB RS 22) BP (BP Energol CS 22) ESSO (Coray 22) SHELL (SHELL Carnea Oel 22)

#### 7.1.2 Lubricating grease

Designation acc. to DIN 51825	Designation	Consistency Index NLGI Class as per DIN 51818	Worked penetration as per DIN ISO 2137	Manufacturer
KP2K-20	Lubricating grease for bearing	NLGI-2	265-295	AVIA (AVIALITH 2) BP (Energrease L2) ESSO (Beacon 2) KLÜBER (CENTOPLEX 2 EP) MOBIL (Mobilux 2) SHELL (Alvania R 2)

## 7.2 Greasing points

The following points of the gun need to be greased regularly. You will find a maintenance-set including grease and corrosion preventive-oil-spray in the spare parts lists in chapter 9.6 und 9.8.

To grease the gun it must be partially dismantled (see hereto chapter 6 "Faults and trouble shooting". We recommend taking the opportunity and greasing the gun when replacing the wear parts.

No.	Designation	Service to be done	Consumables Measured values	Frequency	Notes
1	Trigger	Lubricate with oil	Lubricating oil DIN 51501-L-AN 22	quarterly	Oil trigger slightly
2	Piston	Lubricate with grease	Lubricating grease DIN 51825-KP2K-20	yearly	Grease surface of piston slightly

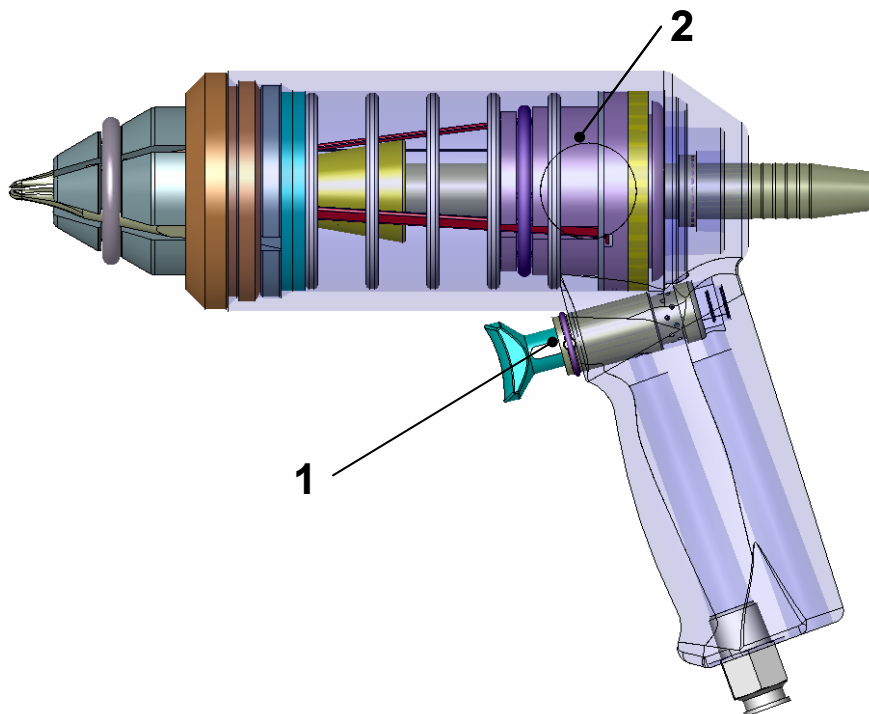

## 7.3 Maintenance

We are working with water to insert the studs, therefore the head of the gun shall be sprayed regularly with anticorrosive material to avoid corrosion and extend lifetime of the gun.



## 8 Shutdown and dismounting

OKU takes back your gun. We recommend you have OKU professionally dismantle the gun and dispose of it.



### Tip!

**Be part of the environmental protection by recycling valuable materials.**

What?		Where?
Transport material	Pallets	Return to the manufacturer or forwarder
	Packing material	Cardboard boxes to waste paper plastic to plastic recycling or waste material reuse wood-wool or waste material
Lubricants	Oil, grease	Dispose according to the valid regulations
Components	Used materials: aluminium aluminium cast grey cast iron steel brass plastic	Separate valuable substances and dispose

## 9 Spare and wear parts

### 9.1 Requirements



**Stop!**

**Spare and wear parts must be in accordance with the technical requirements stipulated by the manufacturer.**

### 9.2 Handling of order

To ensure punctual handling of orders, please state always the **OKU-ID.-No.** of the spare part you need when ordering. You'll find the **OKU-Id.-No.** on the drawing of the gun and the spare parts list.

### 9.3 Explanation to the spare parts list

The numbering of the spare parts in the machine drawing corresponds to the item numbers of the spare parts list.

### 9.4 Spare parts-set

To the gun there is available a spare parts-set including the most important wear parts. It contains all in the spare parts list with \* marked parts inclusive grease and corrosion preventive-oil-spray.

OKU-Id.-No. spare parts-set **AS-8:**                   **20015501**

OKU-Id.-No. spare parts-set **AS-9:**                   **20015502**

### 9.5 Exploded drawing AS-8

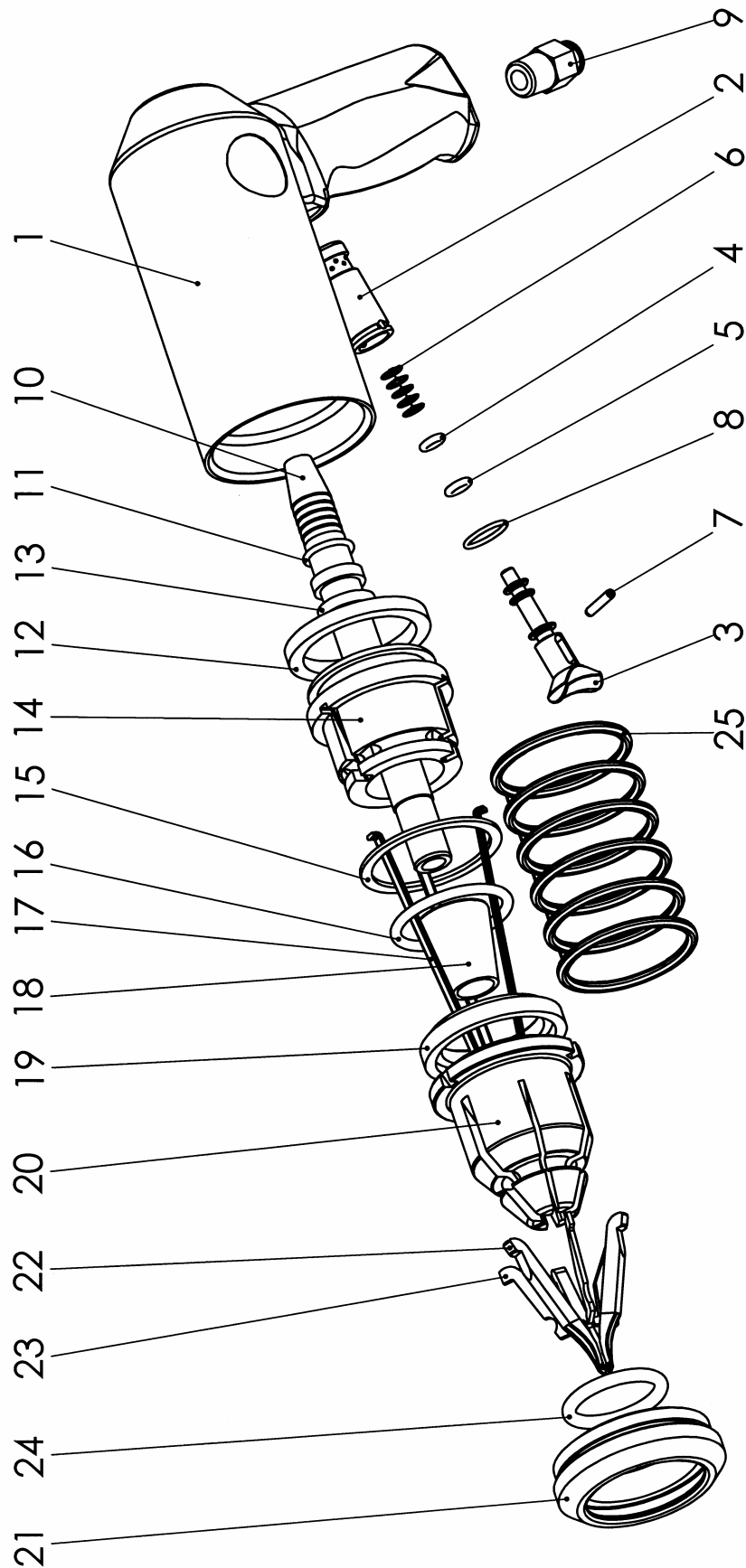

## 9.6 Spare parts list AS-8

Item	OKU-ID.-No.	Qty	Designation
1	00570045	1	Hand grip
2	00350728	1	Bushing
3	00470092	1	Trigger for manual use
	00470093	1	Trigger for machine use
4	00003463	1	O-Ring
5	00003404	1	O-Ring
6	00350297	1	Compression spring
7	00000536	1	Dowel pin
8	00003464	1	O-Ring *
9	00031539	1	Coupling
10	00470084	1	Feeding tube 8,3
11	00003412	1	O-Ring
12	00003507	1	Lip seal
13	00003508	1	Lip seal
14	00470082	1	Piston
15	00350299	1	Washer
16	00003465	1	O-Ring *
17	00470083	3	Insertion pin *
18	00350292	1	Bushing
19	00350733	1	Spacer ring for manual use
	00350734	1	Spacer ring for machine use
20	00470088	1	Head 8
21	00350294	1	Lock nut
22	00470180	3	Special designed spreader fingers *
23	00350295	3	Separating finger
24	00417280	1	Spring lock D=21 *
25	00350298	1	Compression Spring

00885027	1	corrosion preventive-oil, aerosol can 100 ml (single) *
00885028	1	grease, tube 20 g (single) *
20015510	1	1 aerosol can corrosion preventive-oil (100 ml) and 1 tube grease (20 g) as maintenance-set

\* = included in the spare parts-set

### 9.7 Exploded drawing AS-9

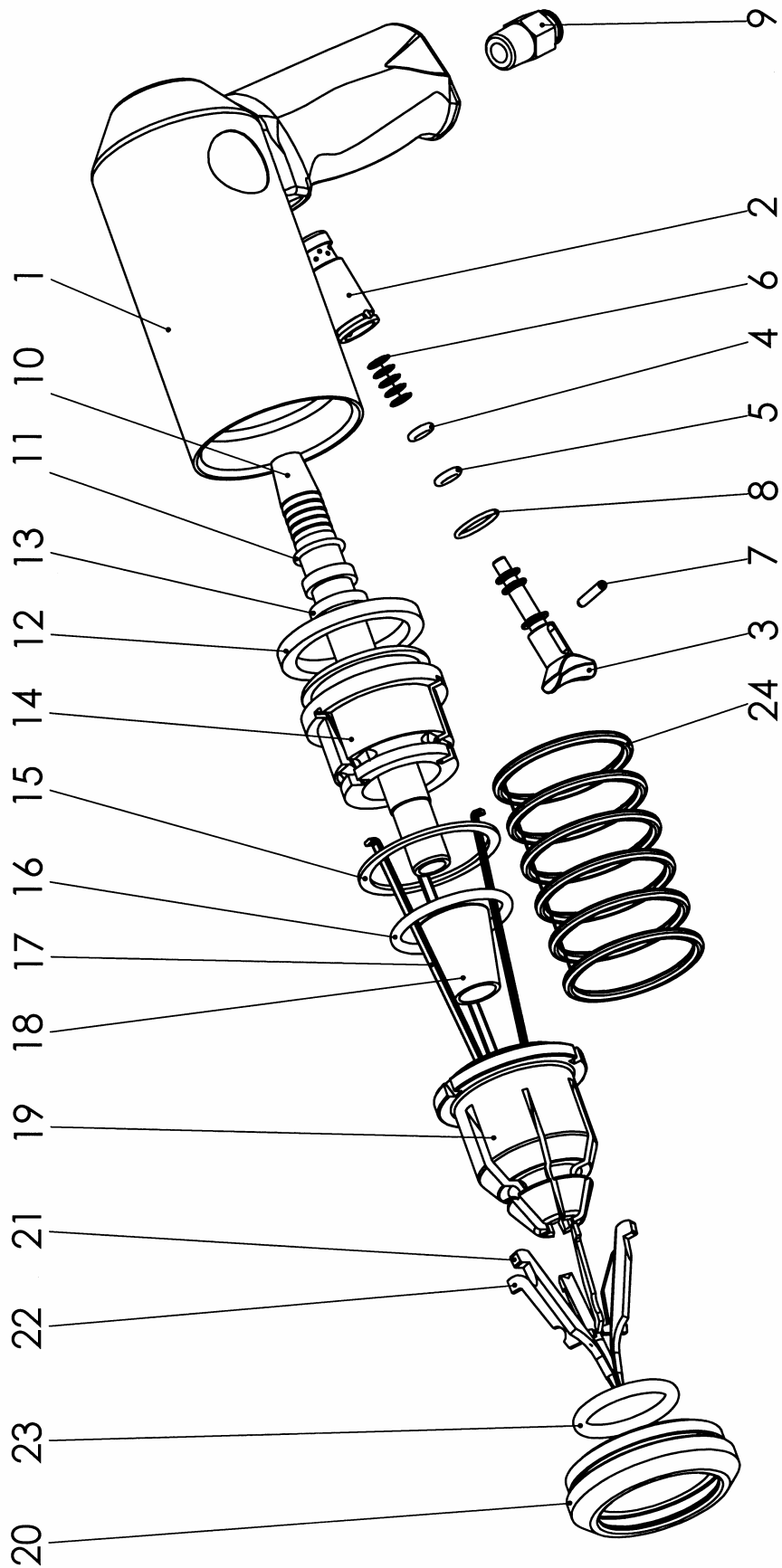

## 9.8 Spare parts list AS-9

Item	OKU-ID.-No.	Qty	Designation
1	00570045	1	Hand grip
2	00350728	1	Bushing
3	00470092	1	Trigger for manual use
	00470093	1	Trigger for machine use
4	00003463	1	O-Ring
5	00003404	1	O-Ring
6	00350297	1	Compression spring
7	00000536	1	Dowel pin
8	00003464	1	O-Ring *
9	00031539	1	Coupling
10	00470085	1	Feeding tube 8,3
11	00003412	1	O-Ring
12	00003507	1	Lip seal
13	00003508	1	Lip seal
14	00470082	1	Piston
15	00350299	1	Washer
16	00003465	1	O-Ring *
17	00470083	3	Insertion pin *
18	00350292	1	Bushing
19	00470089	1	Head 9
20	00350294	1	Lock nut
21	00485167	3	Spreader fingers *
22	00350295	3	Separating finger
23	00417280	1	Spring lock D=21 *
24	00350298	1	Compression Spring
(25)	00350732	1	Spacer ring for machine use

00885027	1	corrosion preventive-oil, aerosol can 100 ml (single) *
00885028	1	grease, tube 20 g (single) *
20015510	1	1 aerosol can corrosion preventive-oil (100 ml) and 1 tube grease (20 g) as maintenance-set

\* = included in the spare parts-set

## 10 Appendix

### 10.1 CE-Declaration of Conformity

# OKU

OKU GmbH  
 Assembly and Feeding Systems  
 Postfach 11 20  
 73643 WINTERBACH  
 GERMANY

Delivery address:  
 Rosenstraße 15  
 73650 WINTERBACH  
 GERMANY

Phone +49 7181 707-0  
 Fax +49 7181 707-170  
 E-Mail [info@oku.de](mailto:info@oku.de)  
 Internet <http://www.oku.de>

### CE Declaration of Conformity

(CE Machine Directive 2006/42/EC, Appendix II A)

The manufacturer: OKU GmbH  
 Assembly and Feeding Systems  
 Rosenstr. 15  
 73650 WINTERBACH, GERMANY

herewith declares that the machine

designation: **Studding gun, models: AS-8, AS-9, EP-8, EP-9, EP-10, EP-12, EP-15, EPK-6,5, EPK-8**

as delivered complies all the relevant regulations of the CE Machine Directive 2006/42/EC.

Harmonized standards applied:

EN ISO 12100-1/A1 Safety of machinery – Basic concepts, general principles for design – Part 1: Basic terminology, methodology  
 EN ISO 12100-2/A1 Safety of machinery – Basic concepts, general principles for design – Part 2: Technical principles

Authorized person to compile the relevant technical documentation:

Armin Layher, Rosenstr. 15, 73650 Winterbach

Winterbach, 01.01.2010

**OKU** GmbH  
 Assembly and feeding Systems

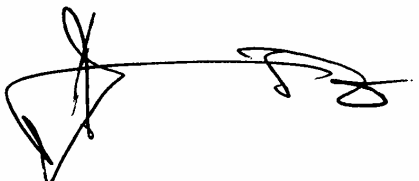

Hans-Joachim Kurz  
 CEO

## 10.2 Copyright

© 01/2010

This documentation is protected by copyright which covers the exclusive rights to reproduce and distribute the documentation, as well as all translation rights. No material published in this documentation may reproduce photographically or stored on microfilm, in electronic data bases, video disks, etc. Technical modifications reserved.

## 10.3 Manufacturer and contact person



OKU GmbH  
Assembly and Feeding Systems  
Rosenstraße 15  
73650 WINTERBACH  
GERMANY

Postfach 11 20  
73643 WINTERBACH  
GERMANY

Phone: +49 7181 707-0  
Fax: +49 7181 707-170  
Internet: <http://www.oku.de>

### Your contact person is:

Sales Department Studs	Phone:	+49 7181 707-0
	Fax:	+49 7181 707-170
	E-Mail:	<a href="mailto:spikes@oku.de">spikes@oku.de</a>