



since
1977

WULKAN Wheel Washers

200

300

300H

360P

360HP

4x4HP

COMBO Q

F1 RACE

500H

500HP

About KART

For 41 years we have been active on the market of garage equipment. For 19 years we have been specialising in manufacturing of automatic wheel washers. We are the sole manufacturer of wheel washers in Poland and one of the leading manufacturers of such machines in the world. Our wheel washers are already used in 35 countries. We are the first to introduce the integrated water heating system. The models that were specifically designed for truck wheels are absolutely unique in the world. We are proud of the high quality and reliability of our wheel washers. This is why WULKAN is the recognizable and highly regarded brand, and the number of our customers



in Poland and abroad is constantly increasing. Our motto is innovation, permanent development and improvement which help our products meet and satisfy the constantly changing needs and requirements of our customers. Our advantage is flexibility which helps us compete effectively on this demanding market. This is why KART is a recognizable and highly regarded trademark. The Company's seat is located in Warsaw. Our products are offered to customers in Poland and abroad through a network of distributors. The premium quality of our products is guaranteed and confirmed by a CE mark. We are also the ISO 9001-2015 Quality Certified.

About WULKAN wheel washers

A wheel washer is a machine which supports servicing of wheels. It is used for technological washing of full car wheels, consisting of the rim and the tyre. The efficiency of technological washing in the WULKAN wheel washers is sufficient for the wheel to be subjected to any servicing activities and meets the necessary requirements in this scope. Using the wheel washer for washing the wheel before servicing activities such as balancing makes the job more precise. This translates directly into safety and comfort of driving.

All our wheel washers have the following features:

- they are fully automatic
- they use the washing method consisting in striking the wheel with a pressurized mixture of water and the WULKAN MIX granulate, with addition of the WULKAN TURBO washing concentrate
- they operate in a closed-circuit water system

- they use the natural self-cleaning method based on sedimentation phenomenon
- they are easy to install and operate
- they save energy
- they are equipped with ergonomic housing
- they are environmentally friendly

Benefits of WULKAN wheel washers:

- high efficiency of the washing process
- easier and more precise servicing operations
- improved driving safety and comfort
- cleaner and neater workshop
- prolonged lifetime of service equipment
- better work environment for the personnel
- working time more effectively used
- improved quality of customer service
- low operating costs



WULKAN COMBO Q with lift WL360

for wheels for passenger cars, vans, off-road vehicles and SUVs up to 360 mm wide with the diameter of up to 850 mm with any type of rims and tyres, including for some racing car wheels with slick tyres, with water heating system, pneumatic wheel stabilisation system and pneumatic wheel loading and unloading system

GENERAL FEATURES

- computer control
- software in 6 languages
- user-friendly display
- rotary pneumatic lift WL360
- servomotor with an arm keeping narrower wheels in vertical position
- integrated system of two smooth drive shafts rotating the wheel
- sedimentation tank separated from washing chamber
- double acoustic insulation system (rubber lining, foam)
- anti-vibration rubber feet
- shut-off ball valve
- attractive graphic design

HEATING SYSTEM

- heater power - 4 kW 400 V
- water heating time to 50°C: 60 - 120 min
- overheating protection

STANDARD EQUIPMENT

- WULKAN MIX granulate 25 kg
- granulate basket
- WULKAN TURBO washing concentrate 30 l
- plastic protective cover
- rubber anti slip mat 2 pcs
- air blow gun

TECHNICAL DATA

Wheel diameter range	560 - 850 mm
Wheel width range	135 - 360 mm
Maximum weight of wheel	60 kg
Washing times, factory set (adjustable, 3 programmes)	20, 40, 60 sec
Drying time, factory set (adjustable, 1 programme)	15 sec
Water heating time to 50°C	60 - 120 min
Heater power	4 kW 400 V
Pump drive 3-phase 400 V, 50 Hz, 5.5 kW	2900 rpm
Pump efficiency	600 lpm
Wheel drive 3-phase 400 V, 50 Hz, 0.55 kW	930 rpm
Motors and drive power	6 kW
Water pressure	4 bar
Quantity of water	300 l
Quantity of WULKAN MIX granulate	20 kg
Quantity of WULKAN TURBO washing concentrate	1.5 l
Compressed air working pressure	8 - 12 bar
Average sound level	77.6 dB(A)
Max. dimensions (width x depth x height)	1885 x 2080 x 1510 mm
Net weight	380 kg
Maximum limiting number of washing process starts (service lock)	500 starts

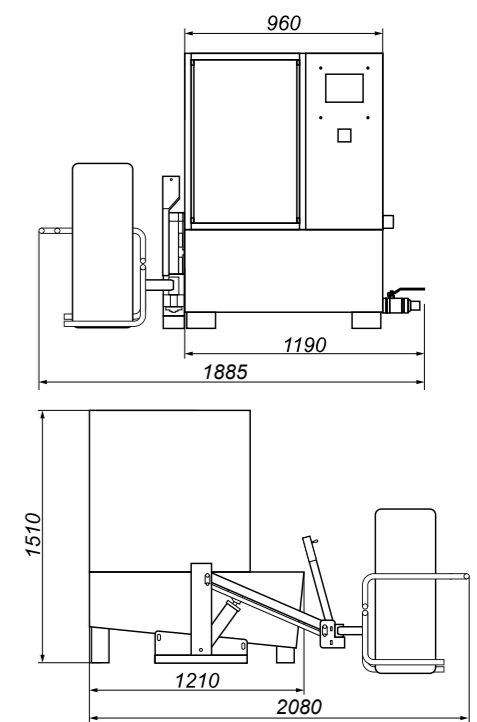

WULKAN 4x4HP

with lift WL360 (option)

for wheels for passenger cars, vans, off-road vehicles and SUVs up to 360 mm wide with the diameter of up to 850 mm with any type of rims and tyres, with water heating system, pneumatic wheel stabilisation system and pneumatic wheel loading and unloading system (option)



GENERAL FEATURES

- computer control
- software in 6 languages
- user-friendly display
- pneumatic rotary lift WL360 (option)
- servomotor with an arm keeping narrower wheels in vertical position
- sedimentation tank separated from washing chamber
- double acoustic insulation system (rubber lining, foam)
- anti-vibration rubber feet
- shut-off ball valve
- attractive graphic design

HEATING SYSTEM

- heater power - 4 kW 400 V
- water heating time to 50°C: 60 - 120 min
- overheating protection

STANDARD EQUIPMENT

- WULKAN MIX granulate 25 kg
- granulate basket
- WULKAN TURBO washing concentrate 30 l
- plastic protective cover
- rubber anti slip mat 2 pcs
- air blow gun



TECHNICAL DATA

Wheel diameter range	560 - 850 mm
Wheel width range	135 - 360 mm
Maximum weight of wheel	60 kg
Washing times, factory set (adjustable, 3 programmes)	20, 40, 60 sec
Drying time, factory set (adjustable, 1 programme)	15 sec
Water heating time to 50°C	60 - 120 min
Heater power	4 kW 400 V
Pump drive 3-phase 400 V, 50 Hz, 5.5 kW	2900 rpm
Pump efficiency	600 lpm
Wheel drive 3-phase 400 V, 50 Hz, 0.55 kW	930 rpm
Motors and drive power	6 kW
Water pressure	4 bar
Quantity of water	300 l
Quantity of WULKAN MIX granulate	20 kg
Quantity of WULKAN TURBO washing concentrate	1.5 l
Compressed air working pressure	8 - 12 bar
Average sound level	79.1 dB(A)
Dimensions without lift (width x depth x height)	1190 x 1210 x 1510 mm
Max. dimensions with lift (width x depth x height)	1885 x 2080 x 1510 mm
Net weight without / with lift	330 / 380 kg
Maximum limiting number of washing process starts (service lock)	500 starts

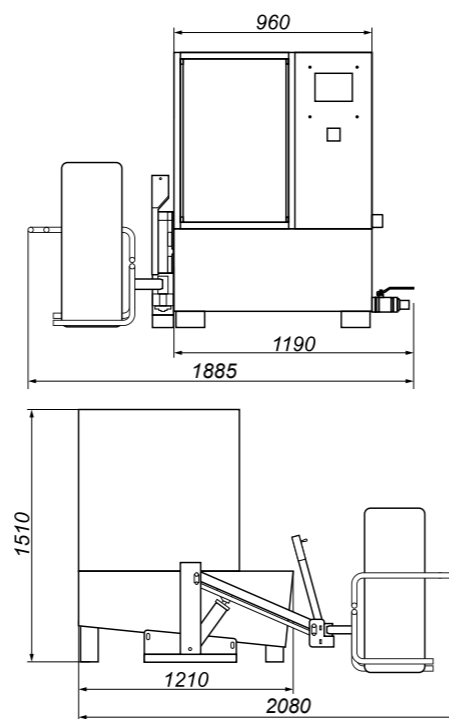

WULKAN 500HP

for bus and truck wheels up to 490 mm wide with any type of rims and tyres, with water heating system and pneumatic wheel loading and unloading system, with additional pneumatic wheel push-out system



GENERAL FEATURES

- computer control
- software in 6 languages
- user-friendly display
- pneumatic rotary lift (2 types: with rim grip or basket)
- pneumatic system pushing the wheel from washing chamber
- sedimentation tank separated from washing chamber
- double acoustic insulation system (rubber lining, foam)
- anti-vibration rubber feet
- shut-off ball valve
- locking handle for washing chamber flap
- functional shelf for accessories
- attractive graphic design

HEATING SYSTEM

- heater power - 4 kW 400 V
- water heating time to 50°C: 120 - 180 min
- overheating protection

STANDARD EQUIPMENT

- WULKAN MIX granulate 50 kg
- granulate basket
- WULKAN TURBO washing concentrate 50 l
- rubber anti slip mat 3 pcs
- air blow gun



TECHNICAL DATA

Wheel diameter range	740 - 1200 mm
Wheel width range	240 - 490 mm
Maximum weight of wheel	150 kg
Washing times, factory set (adjustable, 3 programmes)	60, 120, 240 sec
Drying time, factory set (adjustable, 1 programme)	30 sec
Water heating time to 50°C	120 - 180 min
Heater power	4 kW 400 V
Pump drive 3-phase 400 V, 50 Hz, 5.5 kW	2900 rpm
Pump efficiency	600 lpm
Wheel drive 3-phase 400 V, 50 Hz, 1.1 kW	700 rpm
Motors and drive power	7 kW
Water pressure	4 bar
Quantity of water	500 l
Quantity of WULKAN MIX granulate	40 kg
Quantity of WULKAN TURBO washing concentrate	2 l
Compressed air working pressure	8 - 12 bar
Average sound level	78.3 dB(A)
Max. dimensions with lift with rim grip (width x depth x height)	2180+R x 1950+R x 1902 mm
Max. dimensions with lift with basket (width x depth x height)	2180 x 2510 x 1902
Net weight with lift with rim grip / with basket	630 / 730 kg
Maximum limiting number of washing process starts (service lock)	200 starts

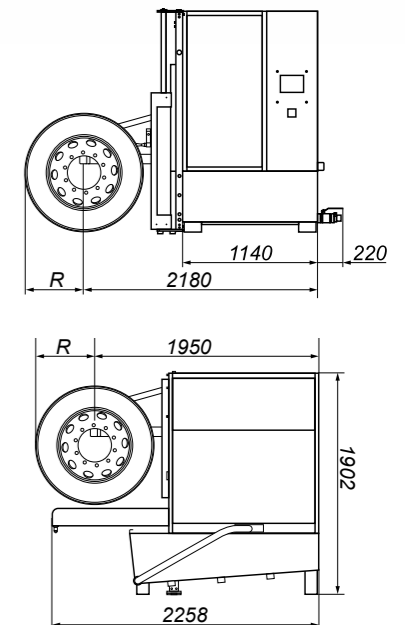
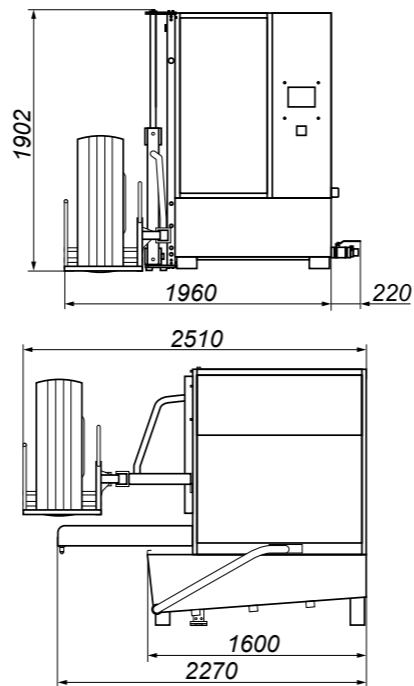

WULKAN 500H

for bus and truck wheels up to 430 mm wide with any type of rims and tyres, with water heating system and pneumatic wheel loading and unloading system

GENERAL FEATURES

- computer control
- software in 6 languages
- user-friendly display
- pneumatic rotary lift with rim grip
- sedimentation tank separated from washing chamber
- double acoustic insulation system (rubber lining, foam)
- anti-vibration rubber feet
- shut-off ball valve
- locking handle for washing chamber flap
- functional shelf for accessories
- attractive graphic design

HEATING SYSTEM

- heater power - 4 kW 400 V
- water heating time to 50°C: 120 - 180 min
- overheating protection

STANDARD EQUIPMENT

- WULKAN MIX granulate 50 kg
- granulate basket
- WULKAN TURBO washing concentrate 50 l
- rubber anti slip mat 3 pcs
- air blow gun



TECHNICAL DATA

Wheel diameter range	740 - 1200 mm
Wheel width range	240 - 430 mm
Maximum weight of wheel	150 kg
Washing times, factory set (adjustable, 3 programmes)	60, 120, 240 sec
Drying time, factory set (adjustable, 1 programme)	30 sec
Water heating time to 50°C	120 - 180 min
Heater power	4 kW 400 V
Pump drive 3-phase 400 V, 50 Hz, 5.5 kW	2900 rpm
Pump efficiency	600 lpm
Wheel drive 3-phase 400 V, 50 Hz, 1.1 kW	700 rpm
Motors and drive power	7 kW
Water pressure	4 bar
Quantity of water	500 l
Quantity of WULKAN MIX granulate	40 kg
Quantity of WULKAN TURBO washing concentrate	2 l
Compressed air working pressure	8 - 12 bar
Average sound level	78.3 dB(A)
Max. dimensions (width x depth x height)	2120+R x 1950+R x 1902 mm
Net weight	630 kg
Maximum limiting number of washing process starts (service lock)	200 starts

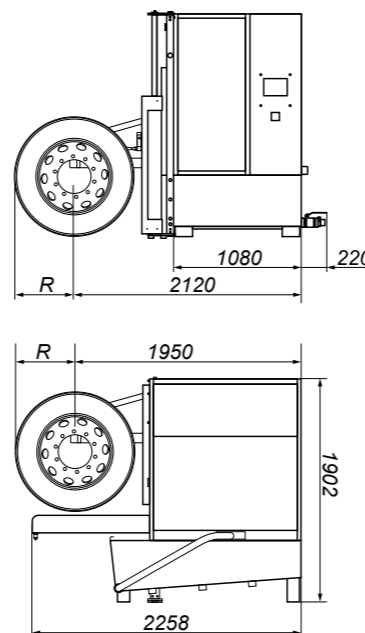

WULKAN F1 RACE

for racing car wheels up to 430 mm wide with slick tyres, with water heating system

GENERAL FEATURES

- computer control
- software in 6 languages
- user-friendly display
- integrated system of two smooth drive shafts rotating the wheel
- sedimentation tank separated from washing chamber
- double acoustic insulation system (rubber lining, foam)
- anti-vibration rubber feet
- shut-off ball valve
- attractive graphic design

HEATING SYSTEM

- heater power - 4 kW 400 V
- water heating time to 50°C: 60 - 120 min
- overheating protection

STANDARD EQUIPMENT

- WULKAN MIX granulate 25 kg
- granulate basket
- WULKAN TURBO washing concentrate 30 l
- plastic protective cover
- rubber anti slip mat 2 pcs
- air blow gun



TECHNICAL DATA

Wheel diameter range	560 - 800 mm
Wheel width range	135 - 430 mm
Maximum weight of wheel	60 kg
Washing times, factory set (adjustable, 3 programmes)	20, 40, 60 sec
Drying time, factory set (adjustable, 1 programme)	15 sec
Water heating time to 50°C	60 - 120 min
Heater power	4 kW 400 V
Pump drive 3-phase 400 V, 50 Hz, 5.5 kW	2900 rpm
Pump efficiency	600 lpm
Wheel drive 3-phase 400 V, 50 Hz, 0.37 kW	930 rpm
Motors and drive power	6 kW
Water pressure	4 bar
Quantity of water	300 l
Quantity of WULKAN MIX granulate	20 kg
Quantity of WULKAN TURBO washing concentrate	1.5 l
Compressed air working pressure	8 - 12 bar
Average sound level	77.6 dB(A)
Dimensions (width x depth x height)	1260 x 1210 x 1450 mm
Net weight	310 kg
Maximum limiting number of washing process starts (service lock)	500 starts

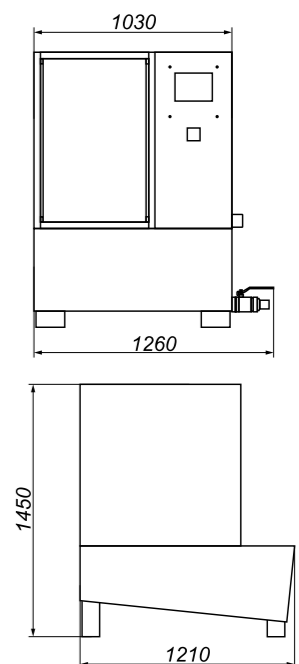

WULKAN 360HP

for wheels for passenger cars, vans, off-road vehicles and SUVs up to 360 mm wide with any type of rims and tyres, with water heating system and pneumatic wheel stabilisation system

GENERAL FEATURES

- computer control
- software in 6 languages
- user-friendly display
- servomotor with an arm keeping narrower wheels in vertical position
- sedimentation tank separated from washing chamber
- triple acoustic insulation system (rubber lining, perforated PVC shield, foam)
- anti-vibration rubber feet
- shut-off ball valve
- attractive graphic design

HEATING SYSTEM

- heater power - 4 kW 400 V
- water heating time to 50°C: 60 - 120 min
- overheating protection

STANDARD EQUIPMENT

- WULKAN MIX granulate 25 kg
- granulate basket
- WULKAN TURBO washing concentrate 30 l
- plastic protective cover
- rubber anti slip mat 2 pcs
- air blow gun

OPTIONAL ACCESSORIES

- pneumatic rotary lift WL360

TECHNICAL DATA

Wheel diameter range	560 - 800 mm
Wheel width range	135 - 360 mm
Maximum weight of wheel	60 kg
Washing times, factory set (adjustable, 3 programmes)	20, 40, 60 sec
Drying time, factory set (adjustable, 1 programme)	15 sec
Water heating time to 50°C	60 - 120 min
Heater power	4 kW 400 V
Pump drive 3-phase 400 V, 50 Hz, 5.5 kW	2900 rpm
Pump efficiency	600 lpm
Wheel drive 3-phase 400 V, 50 Hz, 0.37 kW	930 rpm
Motors and drive power	6 kW
Water pressure	4 bar
Quantity of water	300 l
Quantity of WULKAN MIX granulate	20 kg
Quantity of WULKAN TURBO washing concentrate	1.5 l
Compressed air working pressure	8 - 12 bar
Average sound level	79.5 dB(A)
Dimensions (width x depth x height)	1190 x 1210 x 1450 mm
Net weight	330 kg
Maximum limiting number of washing process starts (service lock)	500 starts

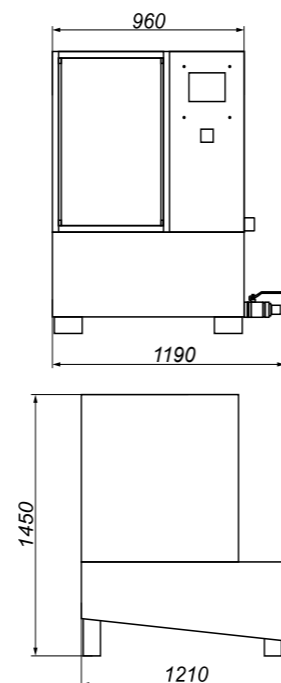

WULKAN 360P

for wheels for passenger cars, vans, off-road vehicles and SUVs up to 360 mm wide with any type of rims and tyres, with pneumatic wheel stabilisation system

GENERAL FEATURES

- servomotor with an arm keeping narrower wheels in vertical position
- sedimentation tank separated from washing chamber
- triple acoustic insulation system (rubber lining, perforated PVC shield, foam)
- anti-vibration rubber feet
- possible adjusting of washing and drying times in the production stage
- counter of starts display option available
- shut-off ball valve
- attractive graphic design on request

STANDARD EQUIPMENT

- WULKAN MIX granulate 25 kg
- granulate basket
- WULKAN TURBO washing concentrate 30 l
- plastic protective cover
- rubber anti slip mat 2 pcs
- air blow gun

OPTIONAL ACCESSORIES

- pneumatic rotary lift WL360

TECHNICAL DATA

Wheel diameter range	560 - 800 mm
Wheel width range	135 - 360 mm
Maximum weight of wheel	60 kg
Washing times, factory set (adjustable, 3 programmes)*	20, 40, 60 sec
Drying time, factory set (adjustable, 1 programme)**	15 sec
Pump drive 3-phase 400 V, 50 Hz, 5.5 kW	2900 rpm
Pump efficiency	600 lpm
Wheel drive 3-phase 400 V, 50 Hz, 0.37 kW	930 rpm
Motors and drive power	6 kW
Water pressure	4 bar
Quantity of water	300 l
Quantity of WULKAN MIX granulate	20 kg
Quantity of WULKAN TURBO washing concentrate	1.5 l
Compressed air working pressure	8 - 12 bar
Average sound level	79.5 dB(A)
Dimensions (width x depth x height)	1190 x 1210 x 1450 mm
Net weight	330 kg
Maximum limiting number of washing process starts (service lock)	500 starts

*/**adjustable only in the production stage

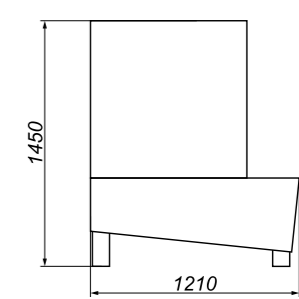
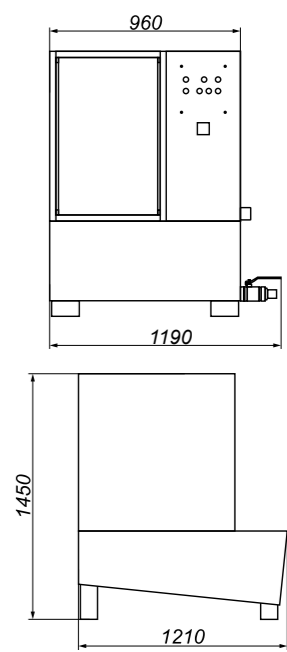

WULKAN 300H

for wheels for passenger cars and vans with any type of rims and tyres, with water heating system

GENERAL FEATURES

- computer control
- software in 6 languages
- user-friendly display
- sedimentation tank separated from washing chamber
- triple acoustic insulation system (rubber lining, perforated PVC shield, foam)
- anti-vibration rubber feet
- shut-off ball valve
- attractive graphic design on request

HEATING SYSTEM

- heater power - 4 kW 400 V
- water heating time to 50°C: 60 - 120 min
- overheating protection

STANDARD EQUIPMENT

- WULKAN MIX granulate 25 kg
- granulate basket
- WULKAN TURBO washing concentrate 30 l
- plastic protective cover
- air blow gun



TECHNICAL DATA

Wheel diameter range	560 - 800 mm
Wheel width range	135 - 305 mm
Maximum weight of wheel	60 kg
Washing times, factory set (adjustable, 3 programmes)	20, 40, 60 sec
Drying time, factory set (adjustable, 1 programme)	15 sec
Water heating time to 50°C	60 - 120 min
Heater power	4 kW 400 V
Pump drive 3-phase 400 V, 50 Hz, 5.5 kW	2900 rpm
Pump efficiency	600 lpm
Wheel drive 3-phase 400 V, 50 Hz, 0.37 kW	930 rpm
Motors and drive power	6 kW
Water pressure	4 bar
Quantity of water	300 l
Quantity of WULKAN MIX granulate	20 kg
Quantity of WULKAN TURBO washing concentrate	1.5 l
Compressed air working pressure	8 - 12 bar
Average sound level	78.4 dB(A)
Dimensions (width x depth x height)	1130 x 1210 x 1450 mm
Net weight	310 kg
Maximum limiting number of washing process starts (service lock)	500 starts

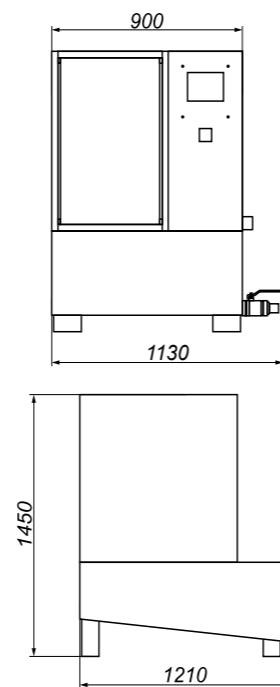

WULKAN 300

for wheels for passenger cars and vans with any type of rims and tyres

GENERAL FEATURES

- sedimentation tank separated from washing chamber
- triple acoustic insulation system (rubber lining, perforated PVC shield, foam)
- anti-vibration rubber feet
- shut-off ball valve
- possible adjusting of washing and drying times in the production stage
- counter of starts display option available
- attractive graphic design on request
- externally mounted water heating system available for retrofitting in older versions of machine

STANDARD EQUIPMENT

- WULKAN MIX granulate 25 kg
- granulate basket
- WULKAN TURBO washing concentrate 30 l
- plastic protective cover



TECHNICAL DATA

Wheel diameter range	560 - 800 mm
Wheel width range	135 - 305 mm
Maximum weight of wheel	60 kg
Washing times, factory set (adjustable, 3 programmes)*	20, 40, 60 sec
Drying time, factory set (adjustable, 1 programme)**	15 sec
Pump drive 3-phase 400 V, 50 Hz, 5.5 kW	2900 rpm
Pump efficiency	600 lpm
Wheel drive 3-phase 400 V, 50 Hz, 0.37 kW	930 rpm
Motors and drive power	6 kW
Water pressure	4 bar
Quantity of water	300 l
Quantity of WULKAN MIX granulate	20 kg
Quantity of WULKAN TURBO washing concentrate	1.5 l
Compressed air working pressure	8 - 12 bar
Average sound level	78.4 dB(A)
Dimensions (width x depth x height)	1130 x 1210 x 1450 mm
Net weight	310 kg
Maximum limiting number of washing process starts (service lock)	500 starts

*/**adjustable only in the production stage

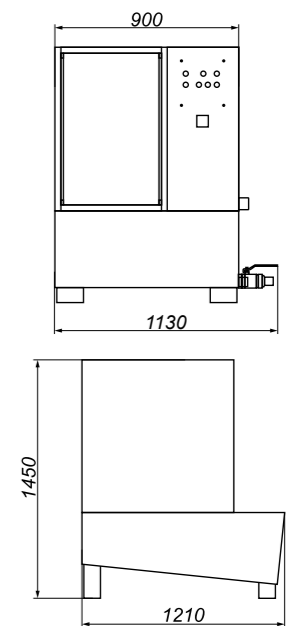

WULKAN 200

for wheels for passenger cars and vans with any type of rims and tyres



GENERAL FEATURES

- triple acoustic insulation system (rubber lining, perforated PVC shield, foam)
- anti-vibration rubber feet
- possible adjusting of washing and drying times in the production stage
- counter of starts display option available
- attractive graphic design on request

STANDARD EQUIPMENT

- WULKAN MIX granulate 25 kg
- granulate basket
- WULKAN TURBO washing concentrate 20 l
- plastic protective cover



TECHNICAL DATA

Wheel diameter range	560 - 800 mm
Wheel width range	135 - 305 mm
Maximum weight of wheel	60 kg
Washing times, factory set (adjustable, 3 programmes)*	20, 40, 60 sec
Drying time, factory set (adjustable, 1 programme)**	15 sec
Pump drive 3-phase 400 V, 50 Hz, 5.5 kW	2900 rpm
Pump efficiency	600 lpm
Wheel drive 3-phase 400 V, 50 Hz, 0.37 kW	930 rpm
Motors and drive power	6 kW
Water pressure	4 bar
Quantity of water	150 l
Quantity of WULKAN MIX granulate	17.5 kg
Quantity of WULKAN TURBO washing concentrate	1.5 l
Compressed air working pressure	8 - 12 bar
Average sound level	78.0 dB(A)
Dimensions (width x depth x height)	970 x 910 x 1360 mm
Net weight	270 kg
Maximum limiting number of washing process starts (service lock)	200 starts

*/**adjustable only in the production stage

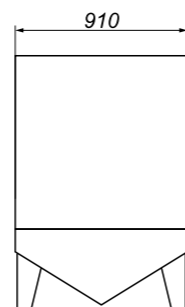
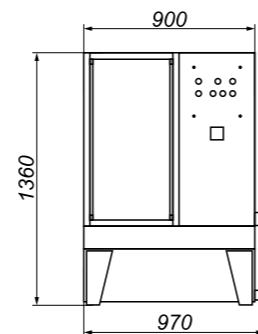

Consumables



WULKAN MIX Granulate 25 kg

This is a mixture of specially selected small round pieces made of biodegradable plastic, with various diameters, weight and hardness. Due to diverse weights and diameters, the pieces distribute uniformly in water in the form of a suspension. The mixture was developed by the KART Company based on many years of experience and tests and ensures the best washing effect without damaging the wheel rim. During washing and cleaning of the washer almost all granulate is recovered. To ensure correct operation of the washer and the best washing results it is important to keep the required level of the working medium. The WULKAN MIX granulate due to its properties practically does not wear out; it is only necessary to add some granulate in order to keep its required quantity in the washing mixture.



WULKAN TURBO Washing Concentrate 10 l

A concentrate of low-foam high-pH preparation made of biodegradable components, specially developed and manufactured for KART to improve the quality and effectiveness of car wheel washing. The dispersant present in the liquid removes all impurities and prevents them from settling on the cleaned surface again, and the surfactant facilitates dissolving various types of operational dirt and contaminants (e.g. brake pad deposits) accumulated on the tyre and rim. Also, use of the liquid makes it easier to keep the wheel washer clean since it prevents the dirt from sticking to the walls of the washing chamber, which facilitates washer cleaning. The corrosion inhibitor present in the liquid protects metal surfaces (wheel rims, rings) from damage. It is diluted with the maximum ratio of 1:100. When refilling water during washer operation, it is important to add the appropriate amount of concentrate each time. It is a washing liquid recommended by KART. If proper proportions are maintained, WULKAN TURBO dissolves in water which can then be safely discharged to the sewer system.

Accessories



Granulate basket



Plastic protective cover

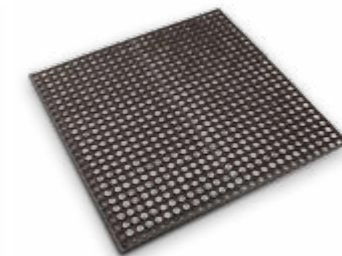

Rubber anti slip mat



Air blow gun

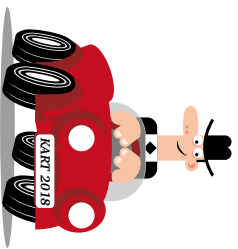

COMPARISON OF WULKAN MODELS

	200	300	300H	360P	360HP	4x4HP / COMBO Q	F1 RACE	500H / 500HP
Wheel diameter range	560 - 800 mm	560 - 800 mm	560 - 800 mm	560 - 800 mm	560 - 800 mm	560 - 850 mm	560 - 800 mm	740 - 1200 mm
Wheel width range	135 - 305 mm	135 - 305 mm	135 - 305 mm	135 - 360 mm	135 - 360 mm	135 - 360 mm	135 - 430 mm	240 - 430 / 490 mm
Maximum weight of wheel	60 kg	60 kg	60 kg	60 kg	60 kg	60 kg	60 kg	150 kg
Washing times (factory set)	20, 40, 60 sec	20, 40, 60 sec	20, 40, 60 sec	20, 40, 60 sec	20, 40, 60 sec	20, 40, 60 sec	20, 40, 60 s	60, 120, 240 sec
Drying time (factory set)	15 sec	15 sec	15 sec	15 sec	15 sec	15 sec	15 s	30 sec
Water heating time to 50°C			60 - 120 min			60 - 120 min		120 - 180 min
Heater power			4 kW 400 V			4 kW 400 V		4 kW 400 V
Pump drive 3-phase 400 V, 50 Hz, 5.5 kW	2900 rpm	2900 rpm	2900 rpm	2900 rpm	2900 rpm	2900 rpm	2900 rpm	2900 rpm
Pump efficiency	600 lpm	600 lpm	600 lpm	600 lpm	600 lpm	600 lpm	600 lpm	600 lpm
Wheel drive 3-phase 400 V, 50 Hz	0.37 kW, 930 rpm	0.37 kW, 930 rpm	0.37 kW, 930 rpm	0.37 kW, 930 rpm	0.37 kW, 930 rpm	0.37 kW, 930 rpm	0.37 kW, 930 rpm	1.1 kW, 700 rpm
Motors and drive power	6 kW	6 kW	6 kW	6 kW	6 kW	6 kW	6 kW	7 kW
Water pressure	4 bar	4 bar	4 bar	4 bar	4 bar	4 bar	4 bar	4 bar
Quantity of water	150 l	300 l	300 l	300 l	300 l	300 l	300 l	500 l
Quantity of WULKAN MIX granulate	17.5 kg	20 kg	20 kg	20 kg	20 kg	20 kg	20 kg	40 kg
Quantity of WULKAN TURBO washing concentrate	1.5 l	1.5 l	1.5 l	1.5 l	1.5 l	1.5 l	1.5 l	2 l
Compressed air working pressure	8 - 12 bar	8 - 12 bar	8 - 12 bar	8 - 12 bar	8 - 12 bar	8 - 12 bar	8 - 12 bar	8 - 12 bar
Average sound level	78.0 dB(A)	78.4 dB(A)	78.4 dB(A)	79.5 dB(A)	79.5 dB(A)	79.1 / 77.6 dB(A)	77.6 dB(A)	78.3 dB(A)
Dimensions (max. with lift) (width x depth x height)	970 x 910 x 1360 mm	1130 x 1210 x 1450 mm	1130 x 1210 x 1450 mm	1190 x 1210 x 1450 mm	1190 x 1210 x 1450 mm	1885 x 2080 x 1510 mm	1260 x 1210 x 1450 mm	2120+R/2180+R x 1950+R x 1902 2180 x 2510 x 1902
Net weight	270 kg	310 kg	310 kg	330 kg	330 kg	380 kg	310 kg	630 / 730 kg
Maximum limiting number of washing process starts (service lock)	200 starts	500 starts	500 starts	500 starts	500 starts	500 starts	200 starts	200 starts

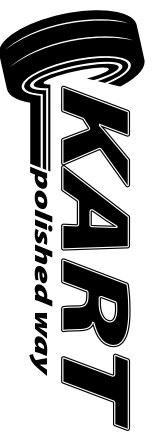

WULKAN
Wheel Washers



KART
Bychowska 22, PL-04-523 Warsaw, Poland
Tel.: +48 22 812 55 05; Fax: +48 22 812 54 04
info@kart.pl; www.kart.pl

