



OKU

Stud Gun

Automatic Stud Gun EP-8, EP-9, EP-10

Operating instructions

(ID-No. 00035102)

00100192 EP-8 (gun for manual use)

00101758 EP-8 (gun for machine)

00100193 EP-9 (gun for manual use)

00100262 EP-9 (gun for machine)

00100194 EP-10 (gun for manual use)

00100263 EP-10 (gun for machine)

assembled:

Date: _____

Name: _____

Table of contents

Table of contents	2
1 Preface and general information	3
1.1 General	3
1.2 Scope of supply	3
1.3 Intended use	3
1.4 Liability	4
1.5 Warranty	4
2 Safety information	5
2.1 Personnel responsible for safety	5
2.1.1 Operator	5
2.1.2 Qualified personnel	5
2.2 General safety instructions	6
2.3 Layout of the safety instructions	6
3 Technical Data	8
3.1 Stud types	8
3.2 Dimensions and weight	8
3.3 Noise emission	9
3.4 Ambient conditions	9
4 Commissioning	10
4.1 Pneumatic connection	10
5 Operation of the gun	11
5.1 Insertion of studs	11
5.2 Faults during insertion	12
5.2.1 Studs inserted to deep	12
5.2.2 Studs jut out off the tire	12
5.3 Conversion of machine gun to manual gun	12
6 Faults and troubleshooting	15
7 Lubrication and maintenance	16
7.1 Lubrication	16
7.1.1 Lubricating oil	16
7.1.2 Lubricating grease	16
7.2 Greasing points	17
7.3 Maintenance	17
8 Shutdown and dismounting	18
9 Spare and wear parts	19
9.1 Requirements	19
9.2 Handling of order	19
9.3 Explanation to the spare parts list	19
9.4 Spare parts-set	19
9.5 Exploded drawing EP-8, EP-9, EP-10	20
9.6 Spare parts list EP-8, EP-9, EP-10	21
10 Appendix	23
10.1 CE-Declaration of Conformity	23
10.2 Copyright	24
10.3 Manufacturer and contact person	24

1 Preface and general information

1.1 General

The operating instructions is used for safe operation of the Stud Guns (in the following referred to as “gun“) type Automatic Stud Gun EP-8, EP-9 and EP-10 (ID-No. 100192, 100193, 100194, 101758, 100262, 100263)). The safety instructions included hereinafter must be observed.

The operating instructions must be available for anybody who is working with the gun and the included instructions must be carefully attended to.

The operating instructions must always be complete and perfectly readable.

1.2 Scope of supply

The delivery normally consists of a stud gun, the operating instruction and 1 separating finger for multi-flange studs fingers (only EP-8 and EP-9). The parts included in your delivery are stated in the accompanying papers.

These papers shall be checked for conformity, immediately after receipt of the goods. OKU GmbH does not provide any guarantee and/or accept any liability for defects complained belatedly.

Therefore:

- Contact the forwarder immediately to complain visible transit damages.
- Contact OKU GmbH immediately to complain visible defects and/or incompleteness of delivery.

1.3 Intended use

The gun is intended to be used only for the insertion of single and multi-flange spikes into tyres of cars.

Any other use shall be deemed to be inappropriate!

1.4 Liability

The information, data and notes of this operating instruction were up-to-date when passing for press. The specifications, illustrations and descriptions included hereinafter do not apply for any previously supplied guns.

We do not accept liability for damages and operating troubles caused by:

- inappropriate use.
- unauthorized modification of gun.
- improper operation of the gun.
- operating errors.
- disregard of this operating instructions.

1.5 Warranty

Conditions of warranty: see Standard Terms and Conditions of OKU GmbH.

Assert warranty claims against OKU GmbH immediately after detection of the defect.

Warranty claims expire in each case in which liability claims cannot be made.

2 Safety information

2.1 Personnel responsible for safety

2.1.1 Operator

Operator is called any natural or legal person who is using the gun and/or on behalf of whom the gun is used.

The operator and/or his safety officer must ensure,

- observance of the relevant regulations, instructions and laws,
- only qualified personnel is working with the gun,
- personnel having the operating instructions available at any time,
- to prohibit non-qualified personnel from working with the gun.

2.1.2 Qualified personnel

As qualified personnel are to be considered persons who were authorised by the safety officer of the plant to perform the necessary activities and who are able to recognise and avoid potential hazards because of their education, experience, instructions and their knowledge about corresponding standards and rules for the prevention of accidents as well as operating conditions (see IEC 364, definition for qualified personnel).

2.2 General safety instructions

These safety instructions do not claim to be exhaustive. In case of any questions, please, contact OKU.

At the time of delivery the gun is state of the art and reliable.

The gun is a source of danger for persons, for the gun itself and for other material assets of the operator, if

- it is operated by unqualified personnel.
- it is used inappropriately.



Operate the gun only when it is in good condition.

Any upgrade, modification or redesign of the gun is basically prohibited. In this case, please confer with OKU.

2.3 Layout of the safety instructions

The safety instructions described hereinafter are arranged consistently.

Beware of personal injury

Pictogram	Meaning	Signal words	Notes
	Warning for hazardous electrical voltage	Danger!	Warns of imminent danger . Consequences of disregarding: Death or very severe injuries
	Warning for general danger	Warning!	Warns of a potential, very hazardous situation . Consequences if disregarded: Death or very severe injuries
	Warning for a general danger	Caution!	Warns of a potential hazardous situation . Consequences if disregarded: Light or minor injuries

Warning of material damage

Icons used	Meaning	Signal words	Notes
	Warning of material damage	Stop!	Warns of potential material damage . Consequences if disregarded: Ambient damage or damage of the gun.

Other information

Icons used	Meaning	Signal words	Notes
	General note	Note!	Designates a general, useful note. Adherence hereof will ease the use of the gun.

3 Technical Data

3.1 Stud types

The gun can be used for the insertion of single-flange and multi-flange studs into car tires. Factory setting is for the insertion of single-flange studs.

To operate the gun with multi-flange studs you'll be needed to convert the gun (not possible for EP-10). Exchange the separating finger (20) of the single-flange studs for the provided separating fingers of the multi-flange studs, as described in chapter 6.7.

Type	ID.-No.	Stud sizes
EP-8 (gun for manual use)	100192	Ø8 from a length of 11 mm Multi-flange studs with a Ø8 and a length of 10 mm can be inserted with gun EPK-8 only.
EP-8 (gun for machine)	101758	
EP-9 (gun for manual use)	100193	Ø8 from a length of 11 mm Ø9 from a length of 11 mm
EP-9 (gun for machine)	100262	
EP-10 (gun for manual use)	100194	Single-flange studs with an Ø10, Ø9 from a length of 13 mm only.
EP-10 (gun for machine)	100263	

3.2 Dimensions and weight

The following values are valid for the gun without any accessories and can differ according to the respective extra equipment.

Length	ca. 282 mm
Width	ca. 60 mm
Height	ca. 194 mm
Weight	ca. 1,8 kg

3.3 Noise emission

The sound pressure level at the work station of the operator can reach up to 83 dB(A). Provide suitable ear protection for the operator.

3.4 Ambient conditions

Use the gun only in closed and dry rooms.

The permissible ambient temperature during operation is from 10 °C to 40 °C.

4 Commissioning

Precautions to be taken before start working with the gun

- Check gun for proper condition.
- Do never operate a damaged gun.

4.1 Pneumatic connection



Attention!

The pneumatic connection is to be made by qualified personnel with extensive knowledge in handling of pneumatic systems.

Screw provided coupling (1) onto the hand grip. Plug compressed air hose into coupling. The gun requires compressed air with approx. 7-8 bar working pressure. The maximum operating pressure amounts to 10 bar.



Coupling (1) for compressed air connection (gun for manual use)

Coupling (1) for compressed air connection (gun for machine)

5 Operation of the gun

5.1 Insertion of studs

Without feeding unit: fill the feeding pipe (13) with approx. 10 studs (flange leading).

With feeding unit: connect the gun with the feeding hose of the studs until feeding pipe (13) is filled with studs (flange leading).

Moisten tire with low surface tension water. To get this, mix normal tap water with some drops of usual dish liquid.



Tip!

Use only less dish liquid to avoid that the inserted stud is pulled out again when extracting the gun.

Insert spreader fingers (23) into one of the moistened tyre holes. Operate the trigger (28) and keep it pressed. The stud is pressed into the tire. Release trigger (28); the gun is now loosen from the tire and the stud is inserted.



Tip!

Put some pressure onto the gun when inserting the studs. With some practice and skill you'll soon find the respective pressure which shall be applied to reach a steady result.

5.2 Faults during insertion

5.2.1 Studs inserted to deep

Reduce the pressure applied on the gun during insertion.

5.2.2 Studs jut out off the tire

Put more pressure onto the gun when inserting the studs.

5.3 Conversion of machine gun to manual gun

If you are using a studding machine (AS-ZN, EP-ZN or EPK-ZN) and want to dismantle the gun from the base frame to use it manually you'll firstly have to convert the gun, i.e. to release the trigger:



Caution!

Disconnect the gun from the compressed air supply.

Release trigger: Slip off O-ring (30) from bushing (32) and dowel pin (29) appears. The dowel pin can be easily pushed out of the bore. The trigger (28) is released and can be removed. Turn the trigger by 90° and insert it back into the bushing. Then insert the dowel pin into the bore of the bushing. Slip the O-ring over and place it into the groove.

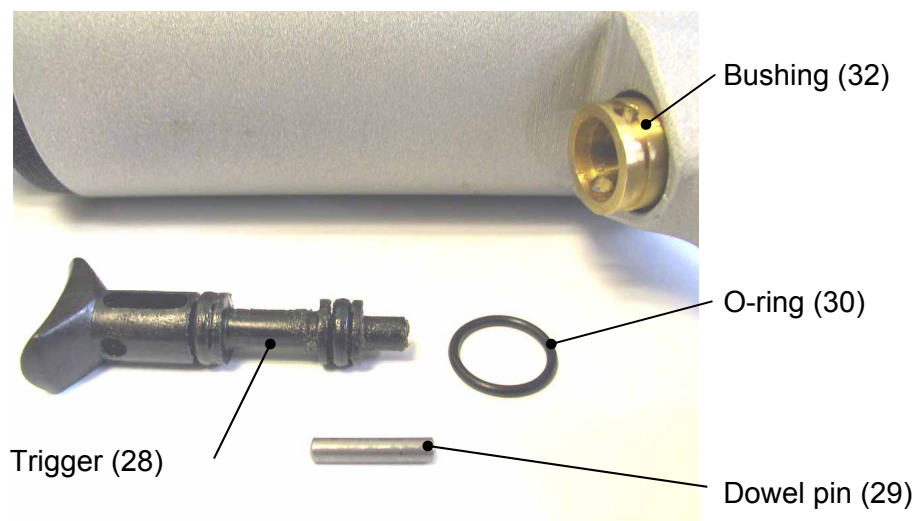
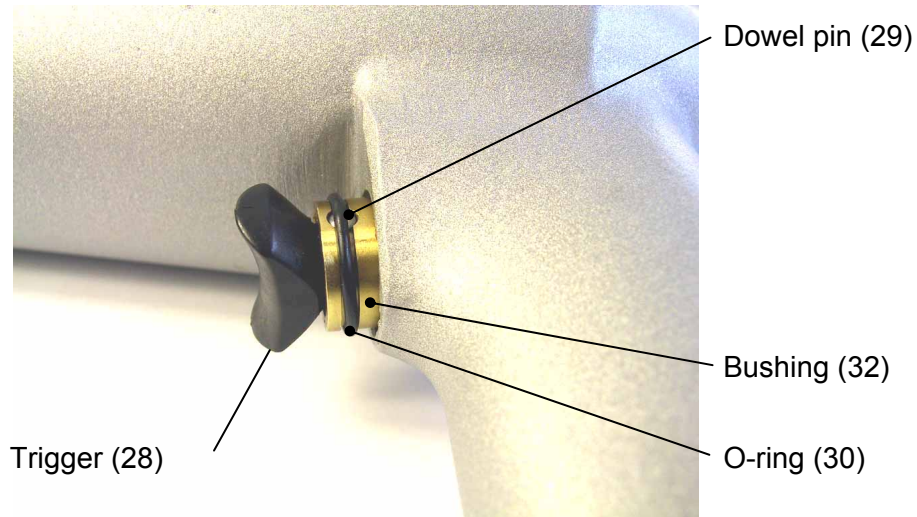

Images similar



Stop!

The gun must be set back to its initial state should you want to use it on the studding machine.

6 Faults and troubleshooting



Caution!

When unscrewing the intermediate piece (17), it must be held tight, because of the strong compression spring which is in the gun. If not, it can be ejected and pose great danger.

No.	Cause	Trouble shooting
6.1	Deformed or dirty stud jammed in feeding pipe (13) or gun head.	Unscrew Union nut (18) and take the head (26) off the gun. Now remove the jammed stud.
6.2	Stud in feeding pipe (13) in wrong position (with shank leading)	Remove feeding tube and shake out stud
6.3	Trigger (28) get caught	Remove O-Ring (30) and dowel pin (29) and then trigger (28). Clean and lubricate trigger slightly with oil. Check if compression spring (3) broken, if so replace compression spring.
6.4	Worn spreader fingers (23)	Unscrew Union nut (18) and take the head (26) off the gun. Remove spring lock (21) and replace spreader finger (23)
6.5	Worn push rod (12)	Unscrew Union nut (18) and take the head (26) off the gun. Unscrew both hexagon head cap screws (27) (Caution!), hold the intermediate piece (17) (pressure of inner springs). Remove intermediate part and circlip (15). Extract push rod (12) together with the springs (10, 11), retaining ring (14) piston disk (6) and lip seal (7). Unscrew hexagon nut (4) and replace worn push rod. Assemble the gun is reversed order and replace hexagon nut if necessary.
6.6	Worn centring finger (24)	Unscrew Union nut (18) and take the head (26) off the gun. Remove spring lock (21), Union nut and O-ring (19). Replace centring finger (24).
6.7	Worn separating finger (20)	Unscrew Union nut (18) and take the head (26) off the gun. Remove spring lock (21), Union nut and O-ring (19). Drive off spring pin (22) with a drift punch until it is possible to remove the separating finger (20). Replace separating finger, consider that the separating finger may not jam it should remain movable.

7 Lubrication and maintenance

7.1 Lubrication



Stop!

Observe the effective directions for the use and safety of the applied lubricants!

7.1.1 Lubricating oil

Distinguishing mark acc. to DIN 51502	Designation	ISO-Viscosity Index DIN 51519	Manufacturer
AN 22	Normal lubricating oil	ISO VG 22	AVIA (AVILUB RS 22) BP (BP Energol CS 22) ESSO (Coray 22) SHELL (SHELL Carnea Oel 22)

7.1.2 Lubricating grease

Designation acc. to DIN 51825	Designation	Consistency Index NLGI Class as per DIN 51818	Worked penetration as per DIN ISO 2137	Manufacturer
KP2K-20	Lubricating grease for bearing	NLGI-2	265-295	AVIA (AVIALITH 2) BP (Energrease L2) ESSO (Beacon 2) KLÜBER (CENTOPLEX 2 EP) MOBIL (Mobilux 2) SHELL (Alvania R 2)

7.2 Greasing points

The following points of the gun need to be greased regularly. You will find a maintenance-set including grease and corrosion preventive-oil-spray in the spare parts list in chapter 9.6.

To grease the gun it must be partially dismantled (see hereto chapter 6 "Faults and trouble shooting". We recommend taking the opportunity and greasing the gun when replacing the wear parts.

No.	Designation	Service to be done	Consumables Measured values	Frequency	Notes
1	Trigger	Lubricate with oil	Lubricating oil DIN 51501-L-AN 22	quarterly	Oil trigger slightly
2	Piston disk Lip seal	Lubricate with grease	Lubricating grease DIN 51825-KP2K-20	yearly	Grease piston surface slightly

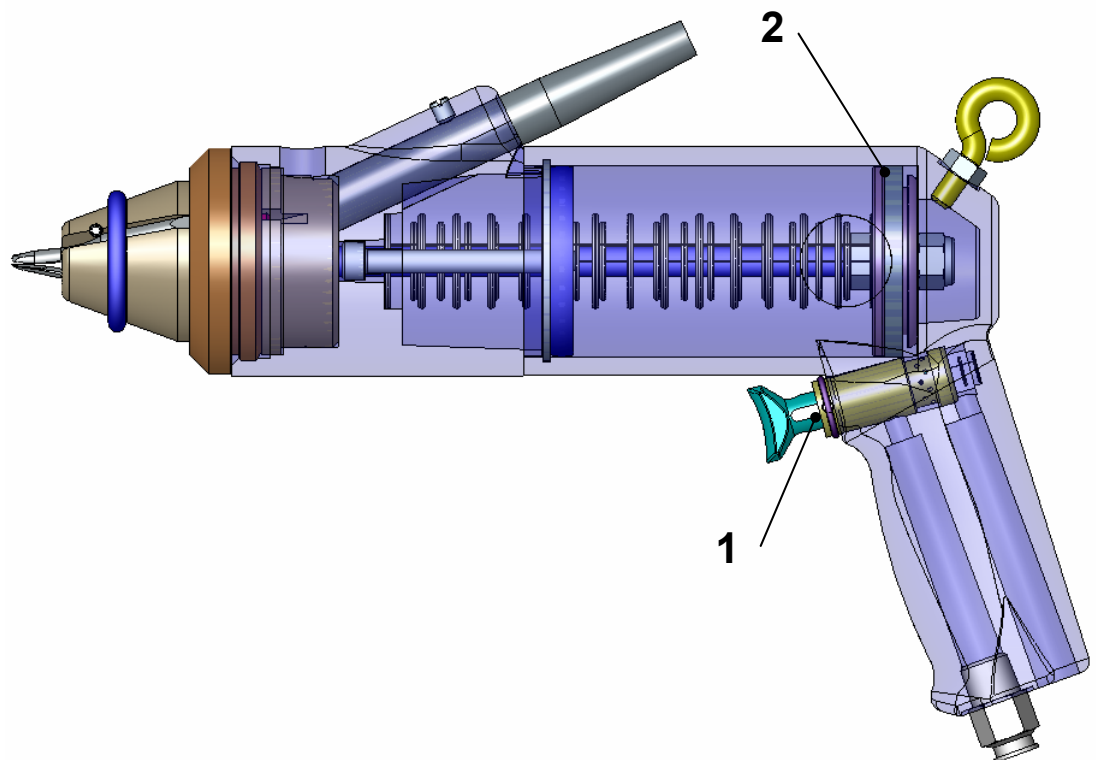

7.3 Maintenance

We are working with water to insert the studs, therefore the head of the gun shall be sprayed regularly with anticorrosive material to avoid corrosion and extend lifetime of the gun.

8 Shutdown and dismounting

OKU takes back your gun. We recommend you have OKU professionally dismantle the gun and dispose of it.



Tip!

Be part of the environmental protection by recycling valuable materials.

What?		Where?
Transport material	Pallets	Return to the manufacturer or forwarder
	Packing material	Cardboard boxes to waste paper plastic to plastic recycling or waste material reuse wood-wool or waste material
Lubricants	Oil, grease	Dispose according to the valid regulations
Components	Used materials: aluminium aluminium cast grey cast iron steel brass plastic	Separate valuable substances and dispose

9 Spare and wear parts

9.1 Requirements



Stop!

Spare and wear parts must be in accordance with the technical requirements stipulated by the manufacturer.

9.2 Handling of order

To ensure punctual handling of orders, please state always the **OKU-ID.-No.** of the spare part you need when ordering. You'll find the **OKU-Id.-No.** on the drawing of the gun and the spare parts list.

9.3 Explanation to the spare parts list

The numbering of the spare parts in the exploded drawing corresponds to the item numbers of the spare parts list.

9.4 Spare parts-set

To the gun there is available a spare parts-set including the most important wear parts. It contains all in the spare parts list with * marked parts inclusive grease and corrosion preventive-oil-spray.

OKU-Id.-No. spare parts-set EP-8:	20015505
OKU-Id.-No. spare parts-set EP-9:	20015506
OKU-Id.-No. spare parts-set EP-10:	20015507

9.5 Exploded drawing EP-8, EP-9, EP-10

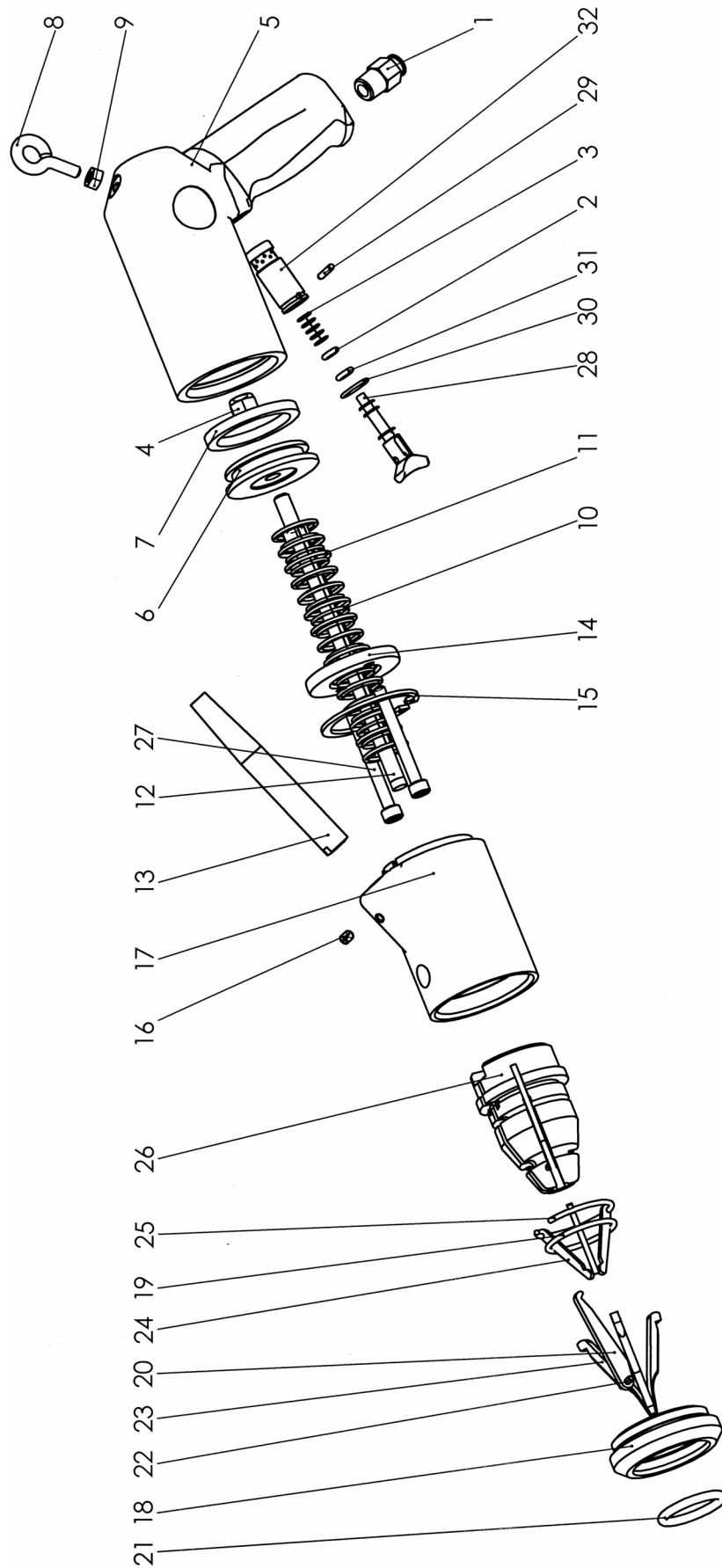

9.6 Spare parts list EP-8, EP-9, EP-10

Item	OKU part No.	Qty	Designation
1	00031539	1	Coupling (for manual use)
	00031547	1	Coupling (for machine use)
2	00003463	1	O-Ring
3	00350297	1	Compression spring
4	00004082	1	Hexagon nut M8
5	00470944	1	Hand grip EP-Car
6	00350667	1	Piston disk
7	00003507	1	Lip seal
8	00000613	1	Eyebolt
9	00000627	1	Hexagon nut M6
10	00350670	1	Compression spring, inner
11	00350669	1	Compression spring, outer
12	00250052	1	Push rod 8 (EP-8) *
	00250051	1	Push rod 9 (EP-9) *
	00250050	1	Push rod 10 (EP-10) *
13	00350671	1	Feeding pipe 8 (EP-8)
	00350711	1	Feeding pipe 9 (EP-9)
	00350726	1	Feeding pipe 10 (EP-10)
14	00350666	1	Retaining ring
15	00000796	1	Circlip
16	00004709	1	Set screw
17	00470185	1	Intermediate piece EP-PKW
18	00350922	1	Union nut
19	00003466	1	O-Ring *
20	00470649	1	Separating finger (single-flange studs)
	00470651	1	Separating finger (multi-flange studs)
21	00417280	1	Spring lock *
22	00000582	1	Spring dowel pin
23	00485167	3	Spreader finger *
24	00353730	3	Centering finger *
25	00350668	1	Lock washer
26	00470214	1	Gun head EP-8
	00470215	1	Gun head EP-9
	00470218	1	Gun head EP-10
27	00004100	2	Hexagon socket head cap screw

Item	OKU part No.	Qty	Designation
28	00470092	1	Trigger (manual use)
	00470093	1	Trigger (machine use)
29	00000536	1	Dowel pin
30	00003464	1	O-ring *
31	00003404	1	O-ring
32	00350728	1	Bushing

00885027	1	corrosion preventive-oil, aerosol can 100 ml (single) *
00885028	1	grease, tube 20 g (single) *
20015510	1	1 aerosol can corrosion preventive-oil (100 ml) and 1 tube grease (20 g) as maintenance-set

* = included in the spare parts-set

10 Appendix

10.1 CE-Declaration of Conformity

OKU

OKU GmbH
 Assembly and Feeding Systems
 Postfach 11 20
 73643 WINTERBACH
 GERMANY

Delivery address:
 Rosenstraße 15
 73650 WINTERBACH
 GERMANY

Phone +49 7181 707-0
 Fax +49 7181 707-170
 E-Mail info@oku.de
 Internet <http://www.oku.de>

CE Declaration of Conformity

for the purposes of CE Machine Directive 98/37/EEC, Appendix II A

Herewith we declare that the machine

designation: Studding gun, models: AS-8, AS-9, EP-8, EP-9, EP-10,
 EP-12, EP-15, EPK-6,5, EPK-8

as delivered is in conformity with the following applicable regulations:

CE Machine Directive version 98/37/EEC, Appendix I, amended by 98/79/EEC

Applicable harmonized standards in particular:

EN ISO 12100-1	Safety of machinery – Basic concepts, general principles for design – Part 1: Basic terminology, methodology
EN ISO 12100-2	Safety of machinery – Basic concepts, general principles for design – Part 2: Technical principles

Winterbach, 30/09/2008

OKU GmbH

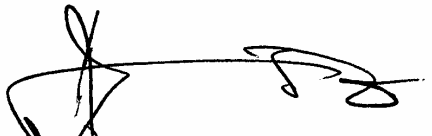

Hans Joachim Kurz
 CEO

10.2 Copyright

© 09/2008

This documentation is protected by copyright which covers the exclusive rights to reproduce and distribute the documentation, as well as all translation rights. No material published in this documentation may reproduce photographically or stored on microfilm, in electronic data bases, video disks, etc. Technical modifications reserved.

10.3 Manufacturer and contact person

The logo for OKU GmbH, consisting of the letters 'OKU' in a bold, blue, sans-serif font.

OKU GmbH
Assembly and Feeding Systems
Rosenstraße 15
73650 WINTERBACH
GERMANY

Postfach 11 20
73643 WINTERBACH
GERMANY

Phone: +49 7181 707-0
Fax: +49 7181 707-170
Internet: <http://www.oku.de>

Your contact person is:

Sales Department Studs	Phone:	+49 7181 707-0
	Fax:	+49 7181 707-170
	E-Mail:	spikes@oku.de