

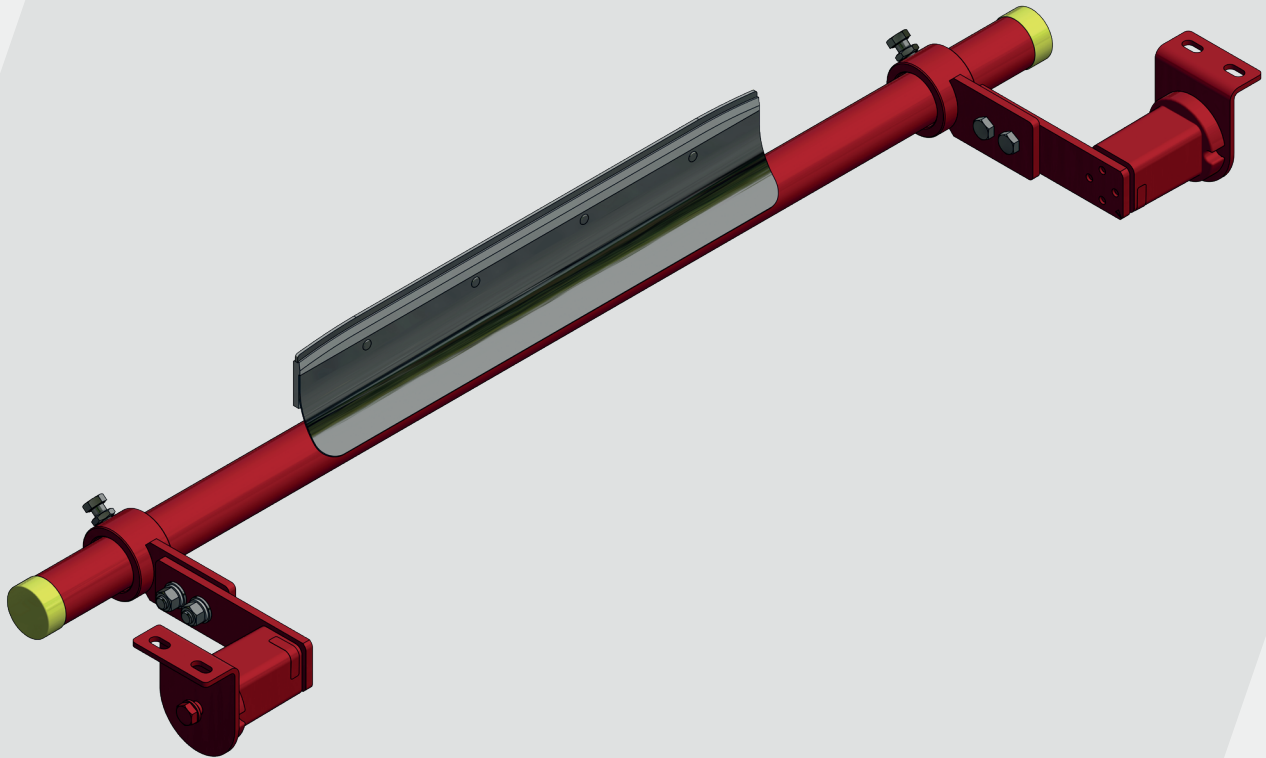

// ONE BRAND // ONE SOURCE // ONE SYSTEM



UNICLEAN HM-UT

Conveyor belt scraper system for belt return side applications with a tungsten carbide blade. The advantage of the system is a low overall height and the torsion pressing device is STANDARD. The UNICLEAN HM-UT is universally applicable for many conveyed goods. The carbide blade adapts to the conveyor belt and thus causes a particularly effective and belt-friendly cleaning. The design of the carbide blade also ensures a long service life and reliability. The combination with the STANDARD pressing device enables a stepless adjustment of the contact pressure, as well as adaptation to a wide variety of installation situations.

CONVEYOR BELT CLEANING SYSTEMS

UNICLEAN – U-Series – for use on the track

UNICLEAN HM-UT

Properties

- very good cleaning effect
- long service life due to trimming with highly wear-resistant solid carbide
- easy installation and adjustment of the system due to the STANDARD pressing device with torsion elements used
- low-maintenance
- low space requirement due to low carbide blade
- automatic adjustment of the system
- for belt widths up to 1,200 mm
- designed for operating temperatures from -40°C to +60°C and belt speeds up to 3.5 m/s
- optionally, mounting brackets with clamping screws can be purchased

Areas of application

- universally applicable for many conveyed goods such as sand, gravel, hard coal, cement, ores



SPARE CARBIDE BLADE

Installation dimensions

Belt width	L1	L2	L3	L4	L5	L6	L7	L8	ROSTA
500	1,000	∅ 48.3	390	450	40	90	110	M12	SE 27
650	1,200	∅ 48.3	490	550	40	90	110	M12	SE 27
800	1,300	∅ 48.3	640	700	50	105	125	M12	SE 27
1,000	1,500	∅ 48.3	840	900	50	105	125	M16	SE 38
1,200	1,700	∅ 60.3	990	1,050	50	105	125	M16	SE 38

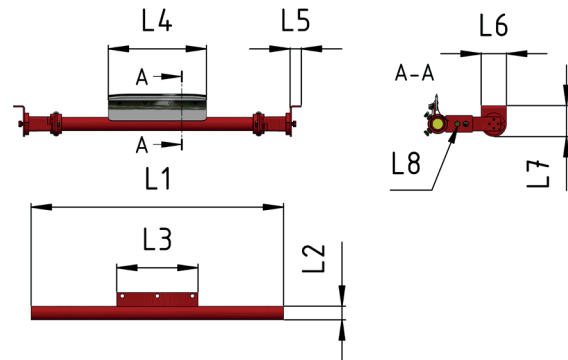

UNICLEAN HM-UT

Art. No.	Description	Belt width
578 8725	UNICLEAN HM-UT	500 mm
578 8726	UNICLEAN HM-UT	650 mm
578 8727	UNICLEAN HM-UT	800 mm
578 8728	UNICLEAN HM-UT	1,000 mm
578 8729	UNICLEAN HM-UT	1,200 mm

Spare strips UNICLEAN HM-UT/HM-UG (90°)

Art. No.	Description	Belt width
578 8730	UNICLEAN HM-UT/HM-UG	500 mm
578 8731	UNICLEAN HM-UT/HM-UG	650 mm
578 8732	UNICLEAN HM-UT/HM-UG	800 mm
578 8733	UNICLEAN HM-UT/HM-UG	1,000 mm
578 8734	UNICLEAN HM-UT/HM-UG	1,200 mm



REMA TIP TOP AG
 Gruber Straße 65 - 85586 Poing / Germany
 Phone: +49 8121 707-100
 Fax: +49 8121 707-10 222
 info@tiptop.de
www.rema-tiptop.com



Your local contact